

## D5: FINAL REPORT

# Coexistence of GSM-R with other Communication Systems ERA 2015 04 2 SC

Made for

### **European Union Agency for Railways**

120, rue Marc Lefrancq

59300 Valenciennes

France



**15.07.2016**

**Version 3**

**Contact:**

Wolfgang Schütz

Tel: +49 (0) 7227-9535-600

Email: [wschuetz@lstelcom.com](mailto:wschuetz@lstelcom.com)



**LS telcom AG**

Im Gewerbegebiet 31-33

77839 LICHTENAU

GERMANY

☎ +49 (0) 7227 9535 600

☎ +49 (0) 7227 9535 605

[Info@LStelcom.com](mailto:Info@LStelcom.com)

[www.LStelcom.com](http://www.LStelcom.com)

## Version Control

Item	Description
Source	LS telcom AG
Client	European Union Agency for Railways
Report Title	D5 –Final Report
Sub Title	Coexistence of GSM-R with other Communication Systems / ERA 2015 04 2 SC
Issue Date	15.07.2016

Version	Date	Description
1	03.06.2016	First submission to the Agency for review
2	29.06.2016	Updated version incorporating revisions following the Agency review
3	15.07.2016	Updated version, with Agency name changed and incorporating last comments from the Agency

---

## Executive Summary

The scope of this study is to analyse if the frequency bands "876-880 / 921-925 MHz" and "873-876 / 918-921 MHz" (ER/R-GSM spectrum) can be shared by other radio communication systems for railway use in coexistence with the existing GSM-R system operated in these frequency bands.

In this context, the European Union Agency for Railways ('the Agency') defined six questions that have been addressed in the scope of the study:

- Q-1: Is it feasible to use an additional radio communication system in the frequency bands "876-880 / 921-925 MHz" and "873-876 / 918-921 MHz" in coexistence with the GSM-R system?
- Q-2: If so, which system, out of the ones specified today or under specification, could be used?
- Q-3: What are the conditions for this coexistence (e.g. in terms of radio parameters, frequency arrangements, network design constraints, terminal requirements)?
- Q-4: Would the specification of the other system studied need to be modified or adapted?
- Q-5: What are the possible consequences for the available capacity of both technologies?
- Q-6: What would be the impact on the current GSM-R networks in terms of redesign?

To answer these questions we used the following approach:

- Firstly, we analysed different radio technologies to determine their suitability for future railway applications. As a result of this analysis we identified LTE / LTE Advanced as, currently, the only practical candidate in the bands under study for the future railway system.
- We performed compatibility analyses to determine the general feasibility and possible frame conditions for sharing scenarios where GSM-R and a LTE 1.4 MHz carrier operate in the same band.
- The theoretical analysis has been complemented by measurements made at the laboratory of the Faculty of Transportation Science, Chair of Transport Systems Information Technology at the Dresden University of Technology.
- We modelled a part of German Railways GSM-R network around Leipzig main station using radio network planning software to determine if the GSM-R network could maintain the existing capacity within the reduced spectrum. We further analysed how much capacity and coverage an LTE network could provide.

Our analysis is necessarily deeply technical and thus the conclusions are not easily accessible by a non-technical reader. In this executive summary, we have therefore provided a synopsis of the main conclusions and recommendations rather than spelling out the detail in full.

Our analysis has shown that:

Conclusion 1: It is **not possible to implement an LTE carrier** within the R-GSM band without a number of technical mitigating measures, most notably:

- A rail LTE network and existing R-GSM service need to be co-sited
- The use of transmitter power control (TPC) for R-GSM user equipment
- The possible need to improve the performance of the LTE user and network equipment

- GSM-R receivers need to meet the requirements identified in ETSI TS 102 933

*Recommendation 1: The extent to which these mitigating measures are necessary or practicable will need to be tested through field trials.*

Conclusion 2: There may be **insufficient capacity** within the existing R-GSM band to allow the co-existence of a 1.4 MHz LTE carrier and GSM services without some degradation to the GSM service.

*Recommendation 2: An assessment of whether these degradations permit acceptable operational performance of the GSM-R service needs to be conducted.*

Conclusion 3: Introducing an LTE 1.4 MHz carrier into the R-GSM band would provide additional data capacity but potentially **reduce the capacity of the GSM-R service**.

*Recommendation 3: An assessment of the future demand for data for rail services needs to be undertaken to determine whether a LTE 1.4 MHz carrier is sufficient and whether additional data capacity demand is foreseen.*

Conclusion 4: In areas where frequency resources are in high demand (e.g. in areas of dense rail traffic or in border areas especially between countries implementing an LTE carrier and those which do not), the **capacity** of both LTE for rail services and GSM-R services **would be severely reduced**.

*Recommendation 4: An assessment of the interoperability problems that could be caused in areas of high traffic demand or where frequency resources are already stretched (e.g. border areas) is required. Existing border arrangements should be re-visited to determine whether sufficient capacity could be obtained to enable effective operation of the rail network.*

# Table of Contents

- 1 SCOPE OF DOCUMENT ..... 8**
- 2 SUMMARY ..... 9**
  - 2.1 Background..... 9
  - 2.2 Approach Taken..... 9
  - 2.3 Summary of Technology Selection .....11
    - 2.3.1 Analysis..... 11
    - 2.3.2 Conclusion .....13
  - 2.4 Summary of Compatibility Analyses ..... 14
    - 2.4.1 Overview .....14
    - 2.4.2 Sharing Calculations..... 15
    - 2.4.3 Intermodulation Analysis .....17
    - 2.4.4 Measurements..... 18
    - 2.4.5 Discussion and Conclusion .....19
  - 2.5 Summary of Network Simulations .....23
    - 2.5.1 Overview .....23
    - 2.5.2 Analysis of remaining Capacity for the existing GSM-R Network .....23
    - 2.5.3 Analysis of achievable Coverage for the LTE Network .....24
    - 2.5.4 Situation in Regions with limited availability of frequencies .....24
    - 2.5.5 Conclusion .....25
- 3 CONCLUSIONS ..... 26**
- 4 ANALYSIS OF CANDIDATE TECHNOLOGIES FOR THE NEW RAILWAY SYSTEM..... 30**
  - 4.1 Analysis.....30
  - 4.2 Conclusion .....36
- 5 SHARING ANALYSES ..... 37**
  - 5.1 Interference Model.....37
  - 5.2 Determination of Antenna Isolation for different Implementation Scenarios....40
    - 5.2.1 Site-to-Site Scenarios .....40
      - 5.2.1.1 Site-to-Site (Same Site, same Antenna) .....40
      - 5.2.1.2 Site-to-Site (Same Site, individual Antennas).....42
      - 5.2.1.3 Site to Site (Individual Sites) .....44
    - 5.2.2 Site-to-Train Scenarios.....47
    - 5.2.3 Train-to-Train Scenarios .....49
      - 5.2.3.1 Use of same Antennas for LTE and GSM-R .....50
      - 5.2.3.2 Use of different Antennas for LTE and GSM-R .....51
    - 5.2.4 Summary on Antenna Isolation Calculations.....53
  - 5.3 Analysis: GSM-R interfered by LTE.....54

---

- 5.3.1 Methodology ..... 54
- 5.3.2 GSM-R Downlink: GSM-R MS interfered by LTE BTS ..... 55
- 5.3.3 GSM-R Uplink: GSM-R BTS interfered by LTE UE..... 60
- 5.3.4 BTS to BTS: GSM-R BTS interfered by LTE BTS..... 65
- 5.3.5 UE to MS: GSM-R MS interfered by LTE UE..... 68
- 5.4 LTE interfered by GSM-R ..... 71
  - 5.4.1 Methodology ..... 71
  - 5.4.2 LTE Downlink: LTE UE interfered by GSM-R BTS ..... 71
  - 5.4.3 Uplink: LTE BTS interfered by GSM-R MS..... 76
  - 5.4.4 BTS to BTS: GSM-R BTS interfered by LTE BTS..... 80
  - 5.4.5 MS to UE: LTE UE interfered by GSM-R MS ..... 83
- 5.5 Summary on Sharing Calculations..... 86
- 6 INTERMODULATION ANALYSIS..... 89**
- 6.1 General ..... 89
- 6.2 Intermodulation Products falling on GSM-R Carriers ..... 90
- 6.3 Intermodulation Products falling in LTE Bandwidth ..... 93
- 6.4 Summary ..... 95
- 7 LABORATORY TESTS ..... 97**
- 7.1 Methodology ..... 97
  - 7.1.1 Approach for Interference Measurements..... 97
  - 7.1.2 General Measurement Setup ..... 99
- 7.2 GSM-R interfered by LTE ..... 101
  - 7.2.1 Equipment configuration ..... 101
  - 7.2.2 Measurement Results ..... 101
- 7.3 LTE interfered by GSM-R ..... 104
  - 7.3.1 Equipment Configuration ..... 104
  - 7.3.2 Measurement Results ..... 104
- 7.4 Summary of Laboratory Tests ..... 109
- 8 NETWORK SIMULATIONS..... 110**
- 8.1 Existing GSM-R Network ..... 111
  - 8.1.1 Coverage and C/I for existing Network (Baseline) ..... 111
  - 8.1.2 Analysis of Channel Requirements for existing Network ..... 114
- 8.2 LTE Network ..... 118
  - 8.2.1 LTE Network using same Sites as existing GSM-R Network..... 118
  - 8.2.2 LTE Network using individual Sites ..... 121
- 8.3 Situation in Border Regions..... 123
  - 8.3.1 GSM-R System ..... 123
  - 8.3.2 LTE System..... 125
- 8.4 Summary of Network Analysis ..... 125
- 9 APPENDIX..... 128**
- 9.1 Abbreviations ..... 128

---

---

9.2	References.....	131
9.3	Other Studies with relevance for this Work .....	133
9.4	Link Budgets .....	136
9.4.1	GSM-R Link Budget .....	136
9.4.2	LTE Link Budget .....	137

---

## **1 Scope of Document**

This document represents the draft final report (Deliverable D5) for the project "Coexistence of GSM-R with other communication systems ERA 2015 04 2 SC" being conducted by LS telcom for the European Union Agency for Railways.

The scope of the document is to give an overview on the project, to detail the performed analyses and to summarize the achieved results.

The report is structured as following:

- Section 2 gives an overview of the used methodology and summarizes results of the individual analyses
- Section 3 summarizes the conclusions of the study
- Section 4 gives a rationale on the technology selection
- Section 5 describes the sharing calculations
- Section 6 gives the results of theoretical intermodulation analyses
- Section 7 includes an overview on the laboratory tests and their findings
- Section 8 describes the done network simulations
- Section 9 contains supporting information like references, list of abbreviations, link budgets



## 2 Summary

### 2.1 Background

The scope of the project is to carry out a study to analyse if the ER/R-GSM spectrum can be shared by other radio communication systems for railway use in coexistence with the existing GSM-R system operated in that frequency band.

Sharing the ER/R-GSM bands with a new radio communication technology might impact both the operation of the GSM-R-System and the additional radio system. In consequence, a degradation of the performance of the existing GSM-R network or the additional radio system is potentially to be expected. At its extreme, the effects could make the use of the system unfeasible, therefore a careful analysis of the effects, their impact on the existing GSM-R system and possible mitigation methods are required.

There is unquestionably a requirement for a successor technology to GSM-R. Therefore, if the feasibility of co-existence in the ER/R-GSM bands is not possible, spectrum in other bands is required. The overarching scope of the study can thus be summarized by the following question:

*Can the ER/R-GSM band be used for a new system or is new spectrum needed?*

Depending of the answer to this question the Agency may need to take further steps. If the results indicate that new spectrum is needed, further Agency activities at EC level will very likely be initiated and the results of the study results may be used by the Agency to inform the Commission and the European Communication Committee about future spectrum needs for a successor to GSM-R.

If results say that ER/R-GSM spectrum can be used (with a set of conditions), or the result is 'can be done but with a reduced voice quality or C/I etc.' then this information will be considered by the Agency for the operational impact of the identified conditions or the impact of voice quality or C/I reduction. In this case, information towards EC and ECC will still be needed to e.g. investigate usage other technologies in the ER/R-band.

### 2.2 Approach taken

It is obvious that sharing the ER/R-GSM bands with a new radio communication technology might impact both the operation of the GSM-R system as well as the additional radio system. In summary three main effects need to be considered:

- Potential RF interference between the radio systems could impact both systems. Depending on the selected frequency arrangements interference might impact uplink and/or downlink and originate from effects like out-of-band emissions at the band edges, spurious emissions, intermodulation effects, receiver blocking etc.
- The band sharing will reduce the spectrum available for the GSM-R system, which might result in reduced capacity, need for higher frequency reuse and/or increased inter-cell interference which in turn could reduce the performance (capacity and/or coverage) of the existing system.
- The additional radio system will require new sites along the tracks to employ radio base stations. Co-siting would be a reasonable approach as the areas to cover will be the same than covered by the GSM-R system. Thus, measures to mitigate interference between GSM-R and LTE BTS due to co-siting could require re-engineering of existing GSM-R sites.

In consequence, a degradation of the performance of the existing GSM-R network or the additional radio system is potentially to be expected. At its extreme, the effects could make

the use of the system unfeasible, therefore a careful analysis of the effects, their impact on the existing GSM-R system and possible mitigation methods are required.

To address these questions an approach with three main elements has been used:

**Technology Selection**

To determine technologies to be included to the study we analysed different radio technologies to assess their suitability for future railway applications. This has been done prior to the other analyses to identify critical technical parameter during the technical analyses of the study.

**Compatibility Analysis**

We performed compatibility analyses to determine the general feasibility and possible frame conditions for sharing scenarios where both systems are operating in the ER/R GSM-R band. For this a generic interference model has been used, where Base Stations (BTS) and Mobile Stations (MS) of both systems have been considered either as source of interference (interferer) or as victim of interference (victim). This model results in eight different interference relations that needed to be analysed:

		Interferer				
		GSM-R		New System		
		BTS	MS	BTS	MS	
Victim	GSM-R	BTS			Interference?	Interference?
		MS			Interference?	Interference?
	New System	BTS	Interference?	Interference?		
		MS	Interference?	Interference?		

Table 2-1: Relevant interference relations

These interference relations have been analysed using analytical sharing calculations for different guard bands  $\Delta f$  between the GSM-R carrier and the carrier of the new system. Two different rollout scenarios, one assuming use of individual sites for GSM-R and the new technology and one assuming the shared use of sites by both technologies have been analysed.

The theoretical analysis has been complemented by measurements at the laboratory of the Faculty of Transportation Science, Chair of Transport Systems Information Technology at the Dresden University of Technology.

**Network Analysis**

We modelled a part of the German Railways GSM-R network around Leipzig main station using radio network planning software to determine the impact of the sharing of the GSM-R spectrum with the new system. The analysis focused on the following questions:

- Can the GSM-R network maintain the existing capacity within the reduced spectrum if the new system is introduced?
- Can a network based on the new technology provide the required capacity and coverage?

In this context also an analysis of the specific situation in border regions has been done, where the available spectrum might be limited due to international coordination agreements.

The following sections of this chapter summarize the analyses and results from these three fields. Details are found in sections 4 to 8.

## 2.3 Summary of Technology Selection

### 2.3.1 Analysis

To determine possible radio technologies for the new railway network a range of candidate technologies has been analysed. While the final functional and technical requirements that need to be supported by the future railway network are not fully specified so far, there are some key requirements that can be applied to determine candidate technologies to be analysed in the frame of the study. The criteria can be distinguished into two different classes:

- **Primary criteria:** These criteria need necessarily to be met to allow the use of the technology for the future and shall already be considered in the existing standards.
- **Secondary criteria:** These criteria need to be met once when the system is implemented, however the implementation could be done in future releases of the system.

The following table lists the key criteria that have been used to assess the technologies:

Category	Type of Criteria and short Description
Carrier bandwidth	<p>Primary criteria</p> <p>The carrier bandwidth of the technology need to fit into the available spectrum (R-GSM and/or ER-GSM bands).</p>
Band availability	<p>Primary criteria</p> <p>The new radio technology need to be available for the ER/R - GSM band (800 MHz), i.e. products are available in a frequency band very close to ER/R-GSM band.</p>
Support of mobility	<p>Primary criteria</p> <p>The standard need to support mobile communications</p>
Open standard	<p>Primary criteria</p> <p>The system shall be an open standard that is developed and supported by different vendors and should be future proof, which means there shall be a clear path for future extensions.</p>
Supported data rate	<p>Secondary criteria</p> <p>The system should be a broadband system to allow for integration of future services.</p> <p>However, there is no general definition of what broadband means in relation to the data rate provided by the system. ITU-R gives some figures in Report M.2033. ETSI uses in TR 102 628 the following definitions that gives an indication of data rates to be provided by narrowband, wideband and broadband systems:</p> <ul style="list-style-type: none"> <li>▪ <b>Narrowband:</b> Communication service providing data rates up to about 100 kBit/s</li> <li>▪ <b>Wideband:</b> Communication service providing higher data rates than narrowband (typically hundreds of kBit/s)</li> </ul>

Category	Type of Criteria and short Description
	<ul style="list-style-type: none"> <li>Broadband: Communication service providing data rates higher than wideband (typically above 1 Mbit/s)</li> </ul> <p>Based on this definition we believe that a future broadband system should support data rates of approximately 1 Mbit/s or more.</p>
Support of services like group call etc.	<p>Secondary criteria</p> <p>The system need to provide railway specific services like group calls or functional addressing as available in GSM-R. However as these features are / can be implemented on higher system layers this could be implemented during a future release of the system. Therefore, this requirement has been defined as secondary.</p>
Support of QoS	<p>Secondary criteria</p> <p>We believe that support of QoS features is necessary for the implementation of the required services, however as this is a feature that can be implemented on higher system layers this could be implemented during a future release of the system. Therefore, this requirement has been defined as secondary.</p>

Table 2-2: Criteria for technology selection

Taking these requirements into account, there remains only a limited number of technologies that might be possible candidates. These candidates could either arise from a set of standards under development for commercial mobile network like recent or upcoming 4G technologies addressed by ITU-R’s IMT-Advanced program. Alternatively, technologies could arise from the field of technologies addressing mission critical networks. The following table summarizes the technologies that have been included to the analysis:

Category	Technologies
3G Mobile Technologies	CDMA 2000 and UMTS with HSPA/HSPA+
4G Mobile Technologies	LTE-(Advanced) and WiMAX (Advanced)
PMR Technologies	DMR, dPMR, NXDN, P25, TETRA including TEDS, TETRAPOL
Other	Wi-Fi

Table 2-3: Systems considered in technology selection

2G mobile technologies (including cdmaOne (IS-95), PDC, IDEN or D-AMPS) have not been seen as possible candidates as GSM-R itself is based on a 2G mobile technology. However, GSM with GPRS and EDGE has been included to the analysis to define the minimum baseline for the future system. 5G Mobile Network technologies are still under research. As no radio interface standards for 5G are available so far, 5G systems have not been further considered. Wi-Fi has been included to the analysis as this technology has been identified by the Next Generation Train Control (NGTC) NGTC Project as possible technology for railway communications in urban areas.

Following our analysis, we found that CDMA2000, LTE-(Advanced), DMR, P25, and TETRA/TEDS would meet the primary criteria.

WiMAX (Advanced) has been excluded, as the technology is currently not available for the 800 MHz frequency range. There have been installations for mobile WiMAX, for example by

Operator Sprint in major US cities. But this network is shutting down and will be replaced by LTE. There are (have been) also only few handsets on the market. A query for smartphones on GSMARENA.com did not come up with any recent handsets. However, USB dongles and end user terminals for wireless local loop applications are available. The latest standard documents also only cover carrier bandwidths of 5 MHz and above. Currently no railway specific services like group calls are available or in standardization process. Thus, in summary we believe that WiMAX is not a probable candidate for replacing GSM-R<sup>1</sup>.

During further analysis, we also excluded DMR and P25 as the data rates provided by these systems would not exceed the rates provided by GSM-R (even without GPRS or EDGE) and thus are no suitable replacements for the existing GSM-R Network.

TETRA release 2 offers TETRA Enhanced Data Services (TEDS) that allows carrier aggregation in a bandwidth of up to 150 kHz and resulting achievable data rates of approximately 500 kBit/s. These data rates slightly exceed the data rates available from GSM with EDGE. However, we believe that the increase in data rates of approximately 100 kBit/s will not justify the rollout of a completely new TETRA network to replace GSM-R, even if the TETRA technology is more recent than GSM. There is also a strong tendency to extend or even replace mission critical TETRA networks with LTE mission critical to provide the bandwidth required by recent applications. In summary, we therefore believe that TETRA (with TEDS) is not a probable candidate for replacing GSM-R.

CDMA 2000 is available for the 800 MHz band, supports mobility and is an open standard. With this CDMA 2000 meets all primary criteria. With up to 3.1 Mbit/s CDMA 2000 would provide broadband data rates. Nevertheless, we do not believe that CDMA 2000 will be used for future railway communications in Europe, as we could not identify a clear roadmap for a future evolution of CDMA 2000. The intended 4G successor to CDMA2000 was UMB (Ultra Mobile Broadband); however, UMB was cancelled because its sponsors favoured Long Term Evolution (LTE).

Long Term Evolution (LTE) Advanced is standardized by the 3GPP (third generation partnership project) and is seen as evolution of LTE to meet the criteria of ITUs IMT Advanced initiative. LTE is available with channel width from 1.4 to 100 MHz also for the 800 MHz band and thus would fit into the target band with a 1.4 MHz carrier. With this LTE meets all primary criteria. LTE supports QoS. In 1.4 MHz carrier width data rates of up to 4 Mbit/s are achievable. The implementation of mission critical services like group calls is ongoing. LTE has also been identified by the Next Generation Train Control (NGTC) project.

### 2.3.2 Conclusion

As a result of the technology evaluation, we identified **LTE / LTE Advanced** as, currently, **the only practical candidate for the future railway system**.

---

<sup>1</sup> As the spectrum masks of LTE and WiMAX have been aligned (e.g. CEPT Report 40 [1]), it is anticipated that interference effects from WiMAX on GSM-R and LTE on GSM-R are comparable. Thus if feasibility (or non-feasibility) of sharing from LTE and GSM-R has been found these result could be transferred insofar to WiMAX, as modifications GSM-R to achieve compatibility with WiMAX are likely to be the same like for LTE, while there might be differences in the degradation of WiMAX performance compared to the ones found during analyses for LTE

## 2.4 Summary of Compatibility Analyses

### 2.4.1 Overview

During technology evaluation, LTE Advanced has been identified as a possible candidate for the future railway radio system. The LTE standard defines different carrier bandwidth from 1.4 MHz up to 20 MHz (without carrier aggregation) in both FDD and TDD mode. With 2x4 MHz paired spectrum in the R-GSM band a 1.4 MHz carrier in FDD mode has been selected for the analyses. Whilst in theory a LTE 3 MHz FDD carrier could be used, this would severely impact the capacity of the GSM-R network to a point where we do not believe it would be possible to provide an operationally effective service. In the longer term, should there be a reduced reliance on the GSM-R service, it may be possible to extend the capacity of the LTE service by increasing the carrier bandwidth.

Different scenarios concerning the location of the LTE carrier within the band are possible. The LTE carrier could be placed at the lower or upper edge of the available band, or a location somewhere within the band. In any case, it is likely that a guard band  $\Delta f$  between the band edge used by GSM-R and the band edge of the LTE carrier is required to minimize interference between the two systems to an acceptable level.

The minimum required guard band depends of the characteristics of the analysed GSM-R and LTE system as well as on the power difference  $\Delta p$  between the wanted and the interfering signal. The power difference  $\Delta p$  in turn depends on parameters of the system implementation such as used transmit powers, cable attenuations, antenna gains and the signal attenuation between the interfered receiver (victim) and the interfering transmitter (interferer).

The signal attenuation between the victim and the interferer is scenario dependent and can be modelled by the antenna isolation that gives the attenuation between the connector of the victim's antenna and the connector of the interferer's antenna.

The antenna isolation thus includes effects of the antenna pattern and the path loss due to wave propagation between the antennas. We analysed different implementation scenarios and determined worst case values.

In a next step, individual sharing calculations have conducted for the eight relevant interference relations considering GSM-R BTS and MS as well as LTE BTS and UE both as interferers and as victims. Interference scenarios have been evaluated in regard to relevant interference effects like system desensitization or degradation due to in-band and adjacent band interfering power and in regard to blocking effects.

As intermodulation (IM) effects are not appropriately considered in the sharing analysis we furthermore performed a theoretical analysis of intermodulation effects to evaluate the number of possible IM products falling in relevant receive bands to gain general insight to possible intermodulation effects.

The theoretical analyses have been complemented by measurements taken at the Laboratory of the Faculty of Transportation Science, Chair of Transport Systems Information Technology at the Dresden University of Technology. A setup using an R&S CMW500 universal tester as base station simulator, a Sagem NNG GPH-99 GSM-R mobile station and a Samsung Galaxy S5 Mini LTE mobile phone has been used. Interfering signals have been generated with a multichannel wideband RF Record & Playback system URT RP-3200 from Averta.

The following sections summarize the results from the individual analyses, a discussion of the results and our conclusion is found in section 2.4.5.

## 2.4.2 Sharing Calculations

As preparation for the sharing calculations, we analysed different implementation scenarios and determined worst case values for antenna isolations for the following scenarios:

- Site-to-Site
- Site-to-Train
- Train-to-Train

The analysis covered additional sub-scenarios like varying isolation between antennas used at the same site etc. Details of the calculations are found in section 5.2.

As a result of the calculations, we identified a value of 45 dB for Antenna Isolation in "Site-to-Site" and "Site-to-Train" scenarios. For "Train-to-Train" scenarios a minimum value of 30 dB has been found in a scenario where two trains with side-mounted antennas pass each other.

In a next step, individual sharing calculations have been done for the eight relevant interference relations considering GSM-R BTS and MS as well as LTE BTS and UE both as interferers and as victims. The analysis has been done for two different network implementation scenarios: one assuming individual sites for GSM-R and LTE, and the other assuming that both networks use the same sites.

To assess the impact of band sharing, the scenarios have been evaluated in regard to relevant interference effects like system desensitization or degradation due to in-band and adjacent band interfering power and in regard to blocking effects.

For each relevant interference effect a margin has been derived, that gives the difference between relevant performance criteria from the 3GPP system standards (e.g. acceptable blocking level) and the value resulting from the analysis (e.g. achieved blocking level). Positive margins indicate that the relevant criteria can be met and thus it is theoretically feasible to share the band between the two technologies. Negative margins indicate cases where the necessary criteria for interoperation cannot be met and thus some form of mitigation may be necessary.

Where appropriate, calculations have been done for guard bands  $\Delta f$  in a range of 200 kHz to 600 kHz between the band edges of the GSM-R carrier and the LTE carrier. For uplink calculations scenarios with and without use of transmit power control (TPC) at the MS / UE has been considered.

The following tables give a summary of the margins that resulted from the different analyses. Several interference effects have been analysed (e.g. blocking and desensitization) for each interference relation, the tables give therefore the smallest margin found from any of the analyses as these indicate the most critical case.

Table 2-4 gives the results for the "Individual Site" scenario assuming a guard band  $\Delta f$  of 200 kHz. The same margins have been found, regardless whether TPC in uplink was considered or not, therefore no individual figures for the two cases are given. Negative margins indicate critical cases and are marked red:

Interferer		Victim			
		GSM-R		LTE	
		BTS	MS	BTS	UE
GSM-R	BTS	-	-	1 dB	-61 dB
	MS	-	-	-45 dB	-47 dB
LTE	BTS	1 dB	-62 dB	-	-
	UE	-55 dB	-19 dB	-	-

Table 2-4: Minimum margins relative to successful interoperation found for “*Individual Site*” scenario

The table indicates several critical margins for the “*Individual Site*” scenario.

The most critical interference situation for this scenario has been found where a mobile station (e.g. a GSM-R MS) is located at the cell edge of its serving cell and at the same site very close to a LTE BTS. In consequence the GSM-R MS is operating with very low receive levels while suffering at the same time under high interference levels from the LTE BTS. As the GSM-R MS uses at the same time high transmit powers to reach the distant GSM-R BTS also high interference levels are found at the nearby LTE BTS. This is reflected by the very low margins for the LTE BTS to GSM-R MS interference of -45 dB and LTE UE to GSM-R BTS interference of -62 dB.

Using TPC at the GSM-R MS in uplink would not improve the situation, as even with TPC enabled the GSM-R MS would use its full transmit power at the cell edge. The same scenario can be sketched for LTE UE interfered by GSM-R BTS, resulting in comparable low margins for the specific cases. An increase of the guard band up to 600 kHz did not result in major improvements. Larger guard bands have not been analysed, as this would no longer allow the use of the LTE 1.4 MHz carrier if only the R-GSM band would be available.

The described scenario where a MS/UE is far from its serving cell and at the same time in close vicinity of an interfering cell can be avoided by coordinated planning of site locations. An extreme of this approach is found when the same site for both systems is used.

Results for this “*Same Site*” scenario with a guard band of 200 kHz are given in the table below. It has been found that the use of TPC is improving the situation in uplink; therefore, figures for both cases are given:



Interferer		Victim			
		GSM-R		LTE	
		BTS	MS	BTS	UE
GSM-R	BTS	-	-	1 dB	-45 dB
	MS	-	-	without TPC: -45dB with TPC:-10.8 dB	-47 dB
LTE	BTS	1 dB	-27 dB	-	-
	UE	without TPC: -62 dB with TPC: 1 dB	-19 dB	-	-

Table 2-5: Minimum margins relative to successful interoperation found for “Same Site” scenario

A comparison of the two scenarios shows that the “Same Site” scenario is less critical than the scenario assuming individual sites. However, TPC is required in uplink, as this feature reduces interference considerably.

Nevertheless, also in the “Same Site” scenario critical margins are found that would need to be mitigated to achieve compatibility. This is further discussed in section 2.4.5.

### 2.4.3 Intermodulation Analysis

GSM-R MS are very sensitive to intermodulation interference, as they need to be capable of operating in frequency bands dedicated for railway use as well as in frequency bands used by public mobile networks. In consequence, interference due to receiver intermodulation has been observed in existing GSM-R networks for example between public mobile networks and GSM-R. Different studies like report FM(13)134 [5] and ECC Report 229 [6] describe intermodulation interference in GSM-R downlink due to LTE. Measurements done in UK showed problems in GSM-R downlink due to intermodulation with UMTS ([7], [8]).

Thus, interference due to intermodulation might also be found in the analysed sharing scenarios, where a LTE carrier is operated within the band dedicated for GSM-R and a further analysis is required.

We therefore performed a theoretical analysis of intermodulation effects to evaluate the number of possible intermodulation products falling in relevant receive bands. The following scenarios have been analysed:

- One LTE 1.4 MHz carrier without any further GSM-R carriers active.
- One LTE 1.4 MHz carrier and one active GSM-R carrier operated with guard bands  $\Delta f$  in a range from 0 - 600 kHz.
- One LTE 1.4 MHz carrier and two active GSM-R carriers with guard bands  $\Delta f$  in a range from 0 - 600 kHz between LTE and the first adjacent GSM-R carrier. A spacing of 400 kHz between the two GSM-R carriers has been considered.
- One LTE 1.4 MHz carrier and all remaining 12 GSM-R carriers of the R-GSM band active at the same time. This is obviously a hypothetical scenario that allows assessing all possible carrier combinations in a worst case scenario, as the number of intermodulation products of different carrier combinations sums up and thus are included in the calculation result.

As a result of the analysis both 3<sup>rd</sup> order products falling into GSM-R carrier bandwidth as well as 3<sup>rd</sup> order products falling into the LTE carrier bandwidth have been identified.

The following tendencies have been derived for 3<sup>rd</sup> order products falling into the GSM-R receive bandwidth:

- The major part of intermodulation products results from interaction of LTE subcarriers with themselves without further interaction with GSM-R carriers; this applies to intermodulation products falling on GSM-R carriers as well as for products falling in the LTE carrier bandwidth.
- The number of intermodulation products falling into a specific GSM-R carrier decrease, the further apart the considered carrier is from the LTE carrier.
- The number of intermodulation products changes only slightly with the guard band  $\Delta f$  between the LTE carrier and the GSM-R carrier active in the calculation.
- The highest number of intermodulation products falling in the receive band for a specific GSM-R carrier is found, if the carrier itself has been active in the calculation.
- Including a second GSM-R carrier into the calculation results only in a minor increase of additional intermodulation products.
- A symmetrical shape of intermodulation products around the LTE carrier is found with decreasing number of products above and below the centre frequency

#### 2.4.4 Measurements

To assess the performance of GSM-R in the presence of a 1.4 MHz carrier, measurements in uplink and downlink have been performed to determine acceptable interference levels to maintain a signal quality of  $RxQual \leq 3$ . Measurements in GSM-R downlink have been performed in a range from -93 dBm up to -35 dBm for the wanted signal, while in uplink measurements have been done for wanted receive levels of -80 dBm and -35 dBm. The measurement yielded the following results for guard bands  $\Delta f$  of at least 200 kHz:

- For the GSM-R downlink, the quality requirement of  $RxQual \leq 3$  can be met if the carrier power of the LTE carrier is not more than approximately 14 dB above the wanted level of the GSM-R connection. For higher receive levels in a range from -35 dBm up to -25 dBm the margin might be smaller but would not fall below 5 dB.
- For the GSM-R uplink, similar figures have been found. The results indicate, that for a guard band of  $\Delta f = 200$  kHz a connection can be maintained with  $RxQual \leq 3$  if the difference between interfering signal and wanted signal  $\Delta p$  does not exceed values of approximately 15 dB. However, it should be noted that, due to limitations in the dynamic range of the measurement setup, evaluations at very low levels for the wanted signal in uplink could not be performed.

Additional measurements have been performed for a 1.4 MHz LTE carrier to assess the reduction in throughput due to interference from an adjacent GSM-R carrier. Measurements in downlink have been performed for QPSK, 16 QAM and 64 QAM configurations at receive levels of -100 dBm. Additional measurements for 64 QAM have been performed for receive levels of -70 dBm. In uplink measurements have been performed for receive levels of -82 dBm (QPSK and 16 QAM) and -50 dBm (16 QAM). The following results have been found for guard bands  $\Delta f$  of at least 200 kHz:

- For LTE downlink receive levels of -100 dBm the reduction of throughput remains below 5% as long as  $\Delta p$  is smaller than 17 dB for 64 QAM, 37 dB for 16 QAM and 44 dB for QPSK. With increasing level of the wanted signal, the system supports higher levels of interfering

power as measurements for 64 QAM at wanted receive levels of -70 dBm resulted in an acceptable  $\Delta p$  of approximately 38 dB.

- The measurement results for uplink shows that the reduction in throughput remains below 5 % as long as  $\Delta p$  does not exceed approximately 22 dB. Thus comparing uplink with downlink measurements it appears that the uplink is more sensitive to the interference from GSM-R than the downlink, where QPSK has been affected for values of  $\Delta p$  approximately above 40 dB. Another interesting observation is that, for both modulation schemes, the decrease in throughput starts at approximately the same value for  $\Delta p$  around 20 dB. While this does not fit to the theory (and the results from the downlink, where QPSK has been more robust than 16 QAM) this effect has been observed and assured by TU Dresden over several measurements.

## 2.4.5 Discussion and Conclusion

### "Individual Site" Scenario

The analysis of the "Individual Site" Scenario indicates critical values for six of the eight analysed interference relations. Only "BTS-to-BTS" interference has been flagged as fully feasible (in the following table, 'green' means feasible and 'amber' means possible but with mitigations):

Interferer		Victim			
		GSM-R		LTE	
		BTS	MS	BTS	UE
GSM-R	BTS	-	-	Green	Amber
	MS	-	-	Amber	Amber
LTE	BTS	Green	Amber	-	-
	UE	Amber	Amber	-	-

Table 2-6: Critical interference relations for the "Individual Site" scenario

The most critical interference situation for this scenario has been found, where a mobile station (e.g. a GSM-R MS) is located at the cell edge of its serving cell and at the same time is very close to a LTE BTS. In consequence the GSM-R MS is operating with very low receive levels while suffering at the same time under high interference levels from the LTE BTS. The analysis resulted in a margin of approximately -55 dB for in-band interfering power resulting in heavy interference. A similar situation might be found for LTE UE at cell edges, where a margin of approximately -60 dB from adjacent carrier interference analysis has been found. This size of margin is very large and it is unlikely (though not impossible) that it could be mitigated with practical and technical measures.

The measurements in downlink showed for both the GSM-R and the LTE downlink that the systems can operate under conditions where the power of the interfering system (measured in the adjacent band) exceeds the power of the wanted signal. However, the found acceptable power differences of 14 dB for the GSM-R downlink and 17 dB for the LTE downlink are not sufficient for worst case of the "Individual Site" scenario.

We therefore conclude that the "Individual Site" Scenario is not feasible.

**“Same Site” Scenario**

Without use of TPC at the mobile station, also six critical interference relations have been found for the “Same Site” Scenario. However if TPC at the LTE UE is used the critical cases can be reduced to five relations (numbered from ① to ⑤):

		Victim				
		GSM-R		LTE		
		BTS	MS	BTS	UE	
Interferer	GSM-R	BTS	-	-		①
		MS	-	-	②	③
	LTE	BTS		④	-	-
		UE		⑤	-	-

Table 2-7: Critical interference relations for the “Same Site” Scenario using TPC in uplink

The table shows that, with respect to the GSM system, with use of TPC for the GSM-R system only interference at the GSM-R MS remains an issue.

The analysis of in-band interfering power in downlink resulted in a margin of +38 dB indicating that at the GSM-R MS no problems due to out-of-band emissions from the LTE BTS are to be expected. This is in contrast to the “Same Site” scenario where the GSM-R downlink suffered from LTE’s out-of-band emissions. The reason is that in the “Same Site” scenario, the GSM-R and LTE signal received by a GSM-R MS are transmitted from the same BTS location and, thus, can be assumed to be in the same range if the BTS antennas for GSM-R and LTE are at similar heights and use similar antenna configurations. We believe that this is a reasonable assumption for sites that intend to cover the same track with both systems.

Nevertheless, a negative margin of -27 dB in GSM-R downlink based on blocking calculations is found (④). However, we believe that the result of the blocking calculations is conservative as the definitions of the acceptable blocking level in the 3GPP specification assume, that the wanted signal is received at levels in the range of the MS receive sensitivity while the “Same Site” scenario is characterized by similar signal levels for wanted and interfering signal. Thus, high blocking levels would always correlate with high levels for the wanted signal and the impact of the blocking is likely smaller than indicated by the calculation. This assumption is supported by the laboratory tests were measurements have been done for  $\Delta f = 200$  kHz, GSM-R downlink wanted receive levels of -35 dBm and -15 dBm and LTE carrier powers of -25 dBm. In both cases, the GSM-R downlink could be operated with an RxQual of 0.

The intermodulation analysis showed that 3<sup>rd</sup> order intermodulation products resulting from the LTE subcarriers falling into the GSM-R carriers receive bandwidth could exist. Interference effects due to intermodulation resulting from LTE has further been reported in different studies, that indicate that signal degradation is to be expected for high levels of the LTE signal. However, in our measurements we could operate the GSM-R downlink in the presence of strong LTE signals, as long as the power of the LTE carrier (measured in the adjacent band) does not exceed the power of the wanted signal by more than approximately 14 dB. This requirement could likely be maintained in the “Same Site” scenario that is characterized by similar receive levels for GSM-R and LTE. The measurements have been performed for a guard band of  $\Delta f = 200$  kHz which constitutes the worst case as our theoretical analysis showed that

the largest number of intermodulation products is found in GSM-R carriers close to the LTE carrier.

The analysis of MS – UE interference indicates a margin of -19 dB (⑤) resulting from desensitization due to spurious emissions of the LTE UE. The result is based on the permissible spurious emissions for the LTE UE. Considering that the relevant receive bandwidth of GSM-R is separated by 45 MHz from the UE transmit frequency these emissions could likely be suppressed by additional filtering at the LTE UE if necessary.

Thus, in summary, we conclude that interference from the LTE System to the GSM-R system can be avoided if the following conditions are fulfilled:

- Use of same sites for GSM-R and LTE with comparable antenna configurations to achieve similar levels for GSM-R and LTE along the track
- Use of transmit power control at the LTE UE to minimize interference in the GSM-R uplink
- Additional filtering at the LTE UE to attenuate LTE's spurious emissions falling in the downlink receive band of the GSM-R MS might be required. Our calculation indicates that an attenuation of approximately 20 dB to attenuate LTE's spurious emissions would be required. This is a relatively high figure and further testing will be necessary to ascertain whether it is feasible to achieve such a level of filtering.

Critical cases for the LTE system are found both at the LTE BTS and the LTE UE:

The uplink calculation shows a margin of -10.8 dB resulting from the assessment of adjacent channel power (②). This figure has been achieved assuming the use of TPC at the GSM-R mobile station while without use of TPC a margin of -45 dB would be found. Thus, additional measures at the LTE BTS, such as additional filtering to improve the adjacent channel selectivity by approximately 11 dB would be required to mitigate this effect. In principle it ought to be possible to achieve such an improvement, as this is not an overly onerous requirement, however testing will be necessary to confirm this. At the same time blocking calculations have been performed. The blocking calculations resulted in a margin of 0 dB thus no severe blocking effects are to be expected.

The blocking calculations for the LTE UE result in a margin of -45 dB which indicates problems due to blocking (①). This assessment is based on a maximum possible interfering level of -10 dBm in the adjacent band at the LTE UE Rx connector and a LTE UE narrow band blocking criteria of -55 dBm. This criteria is defined for a receive level of -80 dBm for the wanted signal. Yet, in the "Same Site" scenario, the GSM-R and LTE signal received by the MS are both in the same range, which means that different conditions as considered by the blocking definition might apply. This assumption is supported by the definition of permissible interfering power in adjacent bands, where at a receive level for LTE of -56 dBm interfering levels in the adjacent band of up to -25 dBm are allowed before the throughput is reduced by more than 5 %. It is therefore anticipated that in the "Same Site" scenarios for LTE receive levels up to -56 dBm no serious degradation of the LTE throughput is to be expected.

The analysis of interference from the GSM-R MS to LTE UE results in a margin of -47 dB originating from the blocking analysis (③). A comparable high figure of -42 dB is found from the analysis of desensitization. However, when assessing these figures it needs to be considered that the separation between GSM-R transmit frequency and the LTE UE receive frequency is approximately 45 MHz. Thus possible blocking effects could be suppressed by adding additional filtering at the LTE UE. Effects due to GSM-R spurious emissions however cannot be suppressed by filtering at the LTE UE as the interfering power falls directly into the LTE receive bandwidth. The margin has been calculated based on worst case assuming permissible out-of-band emissions at the GSM-R MS of -36 dBm in a 100 kHz, resulting in -25 dBm interfering power in a 1.4 MHz bandwidth. This assumption is conservative as, in a

realistic case, the spurious emissions are likely to be concentrated in narrower bandwidth and, thus, would affect only a part of the LTE subcarriers.

Thus in summary we conclude that interference from GSM-R to the LTE network would be too high for successful operation unless the following conditions are met:

- The use of the same sites for both GSM-R and LTE with comparable antenna configurations to achieve similar levels for GSM-R and LTE along the track
- Use of transmit power control at the GSM-R MS to minimize interference in the LTE uplink
- Improvements of the LTE BTS's adjacent channel selectivity
- Improvement of blocking capability at LTE UE

### **Conclusion**

The sharing calculations for the "*Individual Site*" scenario showed that, under worst case conditions, unacceptable interference at cell borders in downlink are to be expected. As this analysis is further supported by the downlink measurements, we conclude that the "*Individual Site*" scenario is not feasible.

For the "*Same Site*" scenario, it has been found that interference levels would still be too high for successful operation unless the following conditions are met:

- The use of the same sites for both GSM-R and LTE with comparable antenna configurations to achieve similar levels for GSM-R and LTE along the track
- The use of transmit power control at the GSM-R MS and the LTE UE
- Additional filtering at the LTE UE to attenuate UE spurious emissions falling in the downlink receive band of the GSM-R MS might be required
- Improvements of the LTE BTS adjacent channel selectivity
- Improvement of blocking capability at the LTE UE

Our calculations identified that approximately 20 dB attenuation of LTE UE spurious emissions might be required. For the improvement of the BTS adjacent channel selectivity, a figure of approximately 11 dB has been calculated. These figures have been calculated based on worst-case assumptions. It is not known whether such requirements could be easily met, and further testing is required to determine the feasibility of applying such mitigation measures.

Several hardware vendors promote base station solutions that support parallel operation of LTE and GSM with a guard band of 200 kHz [23] - [26]. These solutions address the 1800 MHz band but we expect that similar solutions could be made available for the 900 MHz band if required. These may overcome some of the problems above, however it is not certain whether:

- They are available for the R-GSM or ER-GSM bands; or
- They achieve the requirements identified above.

Real-life field tests will be required in order to verify these results, particularly as it is expected that the performance criteria of real equipment may exceed the values in the relevant standards.

## 2.5 Summary of Network Simulations

### 2.5.1 Overview

To determine the impact of the sharing of the GSM-R spectrum with a 1.4 MHz LTE carrier we modelled a part of a GSM-R and LTE network around Leipzig main station with a radio network planning software. For this German Railways provided site data of their existing GSM-R network in a radius of 20 km around Leipzig main station. The network is characterized by the following:

- The analysed network comprises in total 34 different sites
- With 28 sites, the major part of the sites uses two sector antennas to cover the track. The antennas are fed by the same BTS via a power splitter, thus these antennas use the same frequencies and build therefore the same cell.
- 6 sites are equipped with two BTS to build two cells using individual frequencies from the same mast. This includes the BTS at Leipzig main station, where one BTS is used to cover the tracks on the surface while a second BTS is used to cover the subterranean tracks.
- The sites use 19 carriers from the R-GSM-band. ER-GSM frequencies are not used.
- 30 cells use one carrier frequency (TRX) while 5 cells are equipped with 2 TRX. This includes an indoor coverage system for the subterranean parts of Leipzig main station (City tunnel) where an indoor coverage system is employed that uses that individual frequencies that are different from the ones used to cover the surface parts of the station.

### 2.5.2 Analysis of remaining Capacity for the existing GSM-R Network

The introduction of a 1.4 MHz LTE carrier at the edge of the R-GSM band would occupy 8 x 200 kHz (including guard band) thus leaving 11 carriers for the GSM-R network if only frequencies from the R-GSM band were available. To assess if the existing network could be operated with this reduced spectrum we performed two separate analyses:

- We performed a channel assignment using 11 carriers from a continuous bandwidth and compared the resulting C/I in the network with the C/I calculated for the existing frequency plan as provided by German Railways. The analysis showed no considerable reduction in the calculated C/I (i.e. an increase in interference of between 3 and 4 %).
- To assess the impact of future capacity extensions we analysed a network where the number of carriers per cell has been increased by one additional TRX. Our analysis showed that for reasonable interference probabilities below 5 % the network would require between 17 and 28 channels. Thus, the joint use of the R-GSM and the ER-GSM band would be needed for such a network if a 1.4 MHz LTE carrier would also be implemented.

From this, we conclude that, under ideal circumstances, the current capacity requirement could theoretically be operated with 11 carriers but with degradation of the current quality (i.e. an increase in interference of between 3 and 4 %), but that an additional LTE carrier with 1.4 MHz could be accommodated in the R-GSM band within this area. The extent to which the degradation may impact the operational usability of the GSM service would need to be examined. Any increase in demand for capacity on the GSM service would require the additional use of the ER-GSM band to introduce LTE.

Note that in border areas, where there are multiple national systems operating, the remaining 11 carriers would be insufficient to provide the existing levels of capacity and therefore, although within a country such a solution may be operable, in border areas it is not.

### 2.5.3 Analysis of achievable Coverage for the LTE Network

In a second step, two LTE networks have been modelled to analyse network structures required to provide sufficient coverage and throughput:

- In order to assess whether a LTE network using the same sites than GSM-R can provide sufficient coverage along the tracks we simulated LTE network coverage for a network using the existing GSM-R sites. The same antenna configurations have been assumed, but antenna heights have been reduced by 1 m to consider that the antennas are likely to be mounted below the existing GSM-R antennas.
- To assess typical inter site-distances for a network that would have been individually planned for LTE, hypothetical sites have been placed along the main lines around Leipzig main station. The first station of the design has been located at the same position as the existing GSM-R base station in Leipzig main station while the other sites have been selected in a way that continuous coverage is achieved with maximum inter-site distance.

The comparison of the two network designs shows that an LTE network using individual sites could result in slightly larger inter-site distances and thus in a reduced site count. However, the achieved throughput in the network using individual sites is smaller than in the case where the GSM-R sites are used due to the reduced receive level at the cell borders.

The reduction in site count is not so large that a completely re-design of the network during migration to LTE would likely be financially beneficial; in areas of hilly terrain the reduction might be even smaller. Notwithstanding this, our sharing analysis has shown that only co-siting of LTE with GSM-R is potentially feasible.

Nevertheless, both LTE networks configurations would be theoretically capable of providing higher cell-edge downlink data rates than a GSM-R network (even using EGPRS) under ideal propagation conditions. Cell edge data rates in uplink are of a similar order to those provided using EDGE. It is therefore concluded that a LTE network based on a 1.4 MHz LTE carrier would be capable to take over the traffic carried by an existing GSM-R system using legacy GSM-R technology or more recent EGPRS technology.

### 2.5.4 Situation in Regions with limited availability of Frequencies

In regions with limited availability of frequencies, and especially in areas close to the borders, the full ER/R-GSM spectrum might not be available to an operator, as coordination with GSM-R networks in neighbouring countries is required. For this preferential frequencies and coordination criteria are mutually agreed between countries; the agreements typically provides the same or similar number of preferential frequencies per country, either as blocks or interleaved over the band.

Thus using a part of the spectrum for the LTE carrier will not only reduce the spectrum available to GSM-R but could also result in an unequal share of preferential frequencies if existing preferential agreements are not modified.

In consequence a re-negotiation of preferential frequency arrangements would be required if an LTE carrier is introduced. Even if a reorganisation is successful only around 4 preferential frequencies per country would remain which would be not enough if a high GSM-R base station density (e.g. due to larger stations) was found in border regions. Thus, either individual agreements for specific regions or jointly coordinated frequency planning in the border region would be required to provide the required flexibility for the frequency assignment.

Jointly coordinated frequency planning would also be required in situations where in one country LTE would be introduced while in a neighbouring country GSM-R remains in operation. In this case, the spectrum occupied by the LTE carrier in the one country could likely not be



used in the border region of the neighbouring country and would therefore need to be vacated by re-planning the GSM-R channel use in the neighbouring country.

Similar situations, requiring network re-planning, may occur in regions with high traffic density.

For coordination of LTE Physical-Layer Cell Identities (PCI), similar agreements like for GSM-R frequencies could be used. There are in total 504 PCIs available so no problems due to shortcomings of PCIs are expected.

### **2.5.5 Conclusion**

From the network analyses the following conclusions can be drawn.

- The current capacity requirement for the analysed network could be operated with 11 carriers with a degradation of the current quality but that an additional LTE carrier with 1.4 MHz could be accommodated in the R-GSM band within this area. The extent to which any degradation impacted operational usability of the GSM-R network would need to be investigated.
- An increase in demand for capacity would require the additional use of the ER-GSM band to introduce LTE whilst keeping GSM-R service levels adequate.
- Both an LTE network reusing the GSM-R sites as well as network using individual sites would be capable of providing higher downlink cell-edge data rates than a GSM-R network using EGPRS under ideal propagation conditions. Cell edge data rates in uplink are still of the same order as those using EDGE. A LTE network based on a 1.4 MHz LTE carrier would therefore be capable of supporting the traffic carried by an existing GSM-R system using legacy GSM-R technology or more recent EGPRS technology.
- A re-negotiation of preferential frequency arrangements, individual agreements for specific regions or jointly coordinated frequency planning would be required to provide the required flexibility for the GSM-R frequency assignment in border regions. Failing this, the service in border areas would be severely reduced. Similar constraints may occur in areas of high traffic density.
- For coordination of LTE physical-layer cell identities (PCI) similar agreements as for GSM-R frequencies could be used. There are in total 504 PCIs available so we do not envisage significant problems due to shortcomings of PCIs.

### 3 Conclusions

The scope of the study was to analyse if ER/R-GSM spectrum can be shared by other radio communication systems for railway use in coexistence with the existing GSM-R system operated in that frequency band.

In this context, the following six questions have been addressed by the Agency:

- Q-1: Is it feasible to use an additional radio communication system in the frequency bands "876-880 / 921-925 MHz" and "873-876 / 918-921 MHz" in coexistence with the GSM-R system?
- Q-2: If so, which system, out of the ones specified today or under specification, could be used?
- Q-3: What are the conditions for this coexistence? (e.g. in terms of radio parameters, frequency arrangements, network design constraints, terminal requirements...)
- Q-4: Would the specification of the other system studied need to be modified or adapted?
- Q-5: What are the possible consequences for the available capacity of both technologies?
- Q-6: What would be the impact on the current GSM-R networks in terms of redesign?

Question Q-1 is the overarching question of the study. Thus, the answer to Q-1 is found from the answers to questions Q-2 to Q-6. More precisely feasibility is given if the following conditions are fulfilled:

- There is a suitable communication system available or under specification or such a system could be available if specifications would be modified or adapted. This issue is addressed by Q-2 and Q-4.
- The conditions to achieve coexistence are technically feasible. This issue is further addressed by Q-3.
- The resulting capacity under co-sharing for GSM-R and the new system is acceptable (Q-5).
- The required modifications to the design of the existing GSM-R networks (if any) are technically feasible (Q-6).

To verify if these conditions can be met we use the following approach:

- In a first step, we analysed different radio technologies to determine their suitability for future railway applications. As a result of this analysis, we identified LTE / LTE Advanced as, currently, the only practical candidate for the future railway system.
- We performed compatibility analyses to determine the general feasibility and possible frame conditions for sharing scenarios where GSM-R and a LTE 1.4 MHz carrier operates in the same band. The theoretical analysis has been complemented by measurements at the laboratory of the Faculty of Transportation Science, Chair of Transport Systems Information Technology at the Dresden University of Technology.
- We modelled a part of German Railways GSM-R network around Leipzig main station using radio network planning software to determine if the GSM-R network can maintain the existing capacity within the reduced spectrum. We further analysed if a LTE network can provide the required capacity and coverage.

---

As a result of this, we have drawn the following conclusions:

- **LTE Advanced is a suitable communication system.** Railway specific services such as group calls or functional addressing as available in GSM-R would need to be included. Some of these features (e.g. group calls) are already under implementation and foreseen for LTE Release 13.
- It has been found that sharing between GSM-R and LTE within the R-GSM spectrum **is not feasible unless specific technical criteria are met.** Our analyses indicated several conditions that need to be met to achieve compatibility. It has been found that the re-use of the GSM-R sites by LTE and the use of Transmit Power Control at both LTE UE and GSM-R MS is mandatory. Also, improvements at the LTE BTS and LTE UE might be required. We believe that these conditions may be technically feasible but that field-testing is necessary to validate this.
- The network analyses showed that the current capacity requirement of the analysed network could be operated with 11 carriers but with a **degradation of the current quality**, however, an additional LTE carrier with 1.4 MHz bandwidth could, theoretically, be accommodated in the R-GSM band within this area service. Our analysis further showed that an LTE network using a 1.4 MHz carrier would be capable of supporting the traffic carried by an existing GSM-R system using legacy GSM-R technology or more recent EGPRS technology. Thus, we conclude that the resulting capacity under co-sharing for GSM-R and the new system is theoretically acceptable.
- The introduction of LTE requires a shared use of GSM-R sites by LTE. Therefore, a re-engineering of existing GSM-R sites might be needed in some cases to accommodate the additional LTE system technology, feeder cables and antennas.

With this in mind, the following answers to Q-1 to Q-6 have been found:

- Q-1: Is it feasible to use an additional radio communication system in the frequency bands "876-880 / 921-925 MHz" and "873-876 / 918-921 MHz" in coexistence with the GSM-R system?
- A-1: Our analysis has shown that co-existence of LTE and GSM-R within the R-GSM band is not feasible unless a number of technical mitigations are implemented. Further real-life testing is needed to confirm the extent of the need for these mitigations (see question Q-3 and Q-4).
- Q-2: If so, which system, out of the ones specified today or under specification, could be used?
- A-2: During the technology analysis, we identified LTE / LTE Advanced as, currently, the only practical candidate for the future railway system.
- Q-3: What are the conditions for this coexistence? (e.g. in terms of radio parameters, frequency arrangements, network design constraints, terminal requirements...)
- A-3: During our analysis we identified, that the following conditions need to be met to allow for coexistence assuming LTE as future railway system:
- A minimum guard band of 200 kHz between the LTE carrier and GSM-R carriers is required.
  - The use of the same sites for GSM-R and LTE with comparable antenna configurations to achieve similar levels for GSM-R and LTE along the track is mandatory.

- The use of transmit power control (TPC) at both the GSM-R mobile station and the LTE user equipment is mandatory to minimize interference in the uplink.

In addition to this, we identified the need for improvements at the LTE BTS and the LTE UE:

- Additional filtering at the LTE UE to attenuate UE spurious emissions falling in the downlink receive band of the GSM-R MS
- Improvements of the LTE BTS's adjacent channel selectivity
- Improvement of blocking capability at the LTE UE

These requirements are not trivial, however they have been determined based on worst case assumptions.

Real-life field tests will be required in order to verify these results.

Q-4: Would the specification of the other system studied need to be modified or adapted?

A-4: The following adaptations are required:

- Railway specific services such as group calls or functional addressing as available in GSM-R would need to be included. Some of these features (e.g. group calls) are already under implementation and foreseen for LTE Release 13.
- The standard would need to be extended to cover the ER/R-GSM band. With LTE Band 8 (880 – 915 MHz / 925-960 MHz), a specification for the band directly adjacent to the R-GSM band is already available.
- GSM-R MS need to meet the requirements identified in ETSI TS 102 933

In addition, improvements at the LTE BTS and the LTE UE as stated in answer to Question 3 have been found to be required.

Q-5: What are the possible consequences for the available capacity of both technologies?

A-5: The introduction of a 1.4 MHz carrier would occupy 7 GSM-R channels, and depending on the position of the LTE carrier in the ER/R-GSM band, guard bands would occupy one or two additional GSM-R channels.

During the network simulation, we analysed a scenario where the LTE carrier would be located at the upper edge of the R-GSM band because other LTE carrier positions would reduce the remaining GSM-R carriers due to the need for additional guard-bands. The simulations showed a symmetrical behaviour of the resulting intermodulation products so that a positioning of the LTE carrier at the lower edge of the R-GSM band results in the same behaviour as at the upper edge. We found that the current capacity requirement could be maintained with 11 carriers but that this introduced a small degradation (i.e. an increase in interference of between 3 and 4 %) to the current quality, however an additional LTE carrier with 1.4 MHz could, theoretically, be accommodated in the R-GSM band within this area. An increase in demand for capacity would require the additional use of the ER-GSM band to introduce LTE.

Our analysis further showed an LTE network reusing the existing GSM-R sites would be capable of providing downlink cell-edge data rates, which are higher than a GSM-R network using EGPRS. Cell edge data rates in the uplink are still of the same order as those using EDGE. We therefore conclude that an LTE network based on a 1.4 MHz LTE carrier would be capable of supporting the traffic carried by an existing GSM-R

---

system using legacy GSM-R technology or more recent EGPRS technology.

Q-6: What would be the impact on the current GSM-R networks in terms of redesign?

A-6: The introduction of LTE requires shared use of GSM-R sites by LTE. Therefore, a re-engineering of GSM-R sites might be needed in some cases to accommodate the additional LTE system technology, feeder cables and antennas.

We furthermore identified that Transmit Power Control (TPC) in the uplink of the GSM-R network is mandatory. ECC Report 162 indicates that the use of TPC could result in dropped calls due to uplink problems. Therefore, the introduction of additional sites might be required in selected areas.

The frequency plans of the existing networks need to be adjusted to vacate the bandwidth required for the LTE carrier.

There would be a significant reduction in capacity in border areas, which would yield insufficient capacity for the GSM-R network if traffic was significant in those areas. Depending on the network structure a re-negotiation of preferential frequency arrangements, individual agreements for specific regions or jointly coordinated frequency planning in the border regions may ameliorate some of these issues.

Similar situations, requiring network re-planning, may occur in regions with high traffic density.

For coordination of LTE Physical-Layer Cell Identities (PCI) across borders, similar agreements as for GSM-R frequencies could be used. There are in total 504 PCIs available so we do not envisage any significant problems due to shortcomings of PCIs.

## 4 Analysis of Candidate Technologies for the new Railway System

### 4.1 Analysis

To determine possible radio technologies for the new railway network a range of candidate technologies has been analysed. The final functional and technical requirements that need to be supported by the future railway network are not fully specified so far; however, there are some key requirements that can be applied to determine candidate technologies to be analysed in the frame of the study. The criteria can be distinguished into two different classes:

- Primary criteria: These criteria need necessarily to be met to allow the use of the technology for the future and shall already be considered in the existing standards.
- Secondary criteria: These criteria need to be met once when the system is implemented, however the implementation could be done in future releases of the system.

The following table lists the key criteria that have been used to assess the technologies:

Category	Type of Criteria and short Description
Carrier bandwidth	Primary criteria The carrier bandwidth of the technology need to fit into the available spectrum (R-GSM and/or ER-GSM bands).
Band availability	Primary criteria The new radio technology need to be available for the ER/R - GSM band (800 MHz), i.e. products are available in a frequency band very close to ER/R-GSM band.
Support of mobility	Primary criteria The standard need to support mobile communications
Open standard	Primary criteria The system shall be an open standard that is developed and supported by different vendors and should be future proof, which means there shall be a clear path for future extensions.
Supported data rate	Secondary criteria The system should be a broadband system to allow for integration of future services. However, there is no general definition of what broadband means in relation to the data rate provided by the system. ITU-R gives some figures in Report M.2033. ETSI uses in TR 102 628 the following definitions that gives an indication of data rates to be provided by narrowband, wideband and broadband systems: <ul style="list-style-type: none"> <li>▪ Narrowband: Communication service providing data rates up to about 100 kBit/s</li> <li>▪ Wideband: Communication service providing higher data rates than narrowband (typically hundreds of kBit/s)</li> <li>▪ Broadband: Communication service providing data rates higher than wideband (typically above 1 Mbit/s)</li> </ul> Based on this definition we believe that a future broadband system should support data rates of approximately 1 Mbit/s

	or more.
Support of services like group call etc.	<p>Secondary criteria</p> <p>The system need to provide railway specific services like group calls or functional addressing as available in GSM-R. However, as these features are / can be implemented on higher system layers this could be implemented during a future release of the system. Therefore, this requirement has been defined as secondary.</p>
Support of QoS	<p>Secondary criteria</p> <p>We believe that support of QoS features is necessary for the implementation of the required services, however as this is a feature that can be implemented on higher system layers this could be implemented during a future release of the system. Therefore, this requirement has been defined as secondary.</p>

Table 4-1: Criteria for technology selection

Table 4-2 gives an overview on technology categories that have been considered while selecting appropriate technologies, corresponding technical parameter for selected systems are given in Table 4-3.

Category	Description
2G Mobile Network Technologies	<p>These systems have originally been developed for voice services. Later enhancements like GPRS and EDGE upgraded the data transmission capacities; however, no further improvements are expected for 2G technologies in the long term. 2G standards are for example GSM, cdmaOne (IS-95), PDC, IDEN or D-AMPS.</p> <p>The GSM-R system is based on GSM; therefore, GSM with GPRS and EDGE has been included to the analysis to define the minimum baseline for the future system. The other systems have not been further considered, as they are rather outdated and do not provide any further benefit over GSM and its extensions.</p>
3G Mobile Network Technologies	<p>3G technologies mainly originate from the IMT-2000 initiative launched by the International Telecommunication Union (ITU).</p> <p>Within this initiative a range of standards has been developed, targeting to provide mobile broadband communications and voice services. UMTS and CDMA2000 are the most prominent technologies within this category, both relying on spread spectrum radio transmission technology.</p> <p>3G networks were intended to provide higher transmission data rates. Extensions to the initial standard like HSPA and HSPA+ for UMTS further extended the standard towards higher data rates.</p>
4G Mobile Network Technologies	<p>4G technologies originate from the IMT-Advanced initiative of ITU-R.</p> <p>Main features of this standard are the support of all-internet Protocol (IP) based communication, high spectral efficiency with high data rates and low system latencies.</p> <p>Considered 4G technologies are LTE Advanced and WiMAX Advanced. The predecessors of both systems are available on the market and used to extend and replace existing 2G and 3G installations. Specifications for the evolution of these technologies to meet the requirements of IMT Advanced cover for example the inclusion of features to increase the achievable data rates (e.g. Carrier Aggregation, Higher Order Modulation and Coding Schemes, Higher Order MIMO configurations).</p>
5G Mobile Network	<p>Fifth generation mobile networks are still under research. The Next Generation Mobile Networks Alliance (NGMN) is an association founded by the major mobile</p>

Technologies	operators in 2006 that evaluates and develops a common view of solutions for the next evolution of wireless networks. However, at the current time there are only requirement specifications available. As no radio interface standards for 5G are available so far, 5G systems have not been further considered.
Mobile Network Technologies for PMR	<p>Professional mobile radio (PMR) technologies are radio communication systems intended primarily for closed user groups like public safety organizations and critical infrastructure providers. These systems provide specific services like group and broadcast calls, call priorities, low call-setup times and security protocols.</p> <p>These systems can be roughly subdivided into two categories.</p> <p>Systems like TETRA, APCO P25 and TETRAPOL were specifically developed for wide area networks providing service to large user groups like government agencies and public safety users. They can be considered as 2G technologies and support only limited data rates. Only TETRA Release 2 that includes TETRA Enhanced Data Services (TEDS) offers an evolution that supports higher data rates.</p> <p>Other PMR standards like DMR, NXDN and dPMR are addressing professional networks with low user numbers and are widely used to replace existing analogue installations. These systems are not as complex as TETRA or TETRAPOL networks, do typically not provide the same range of services and have limited data capabilities.</p>
Other Technologies	<p>There is a range of other radio technologies that do not directly fit into one of the above listed criteria. These are for example technologies for Wireless Broadband Access (like WiMAX fixed) or Wi-Fi / WLAN. This comprises also a range of proprietary technologies like Flash OFDM that are used in some network implementations but do not have a wide vendor support.</p> <p>From these technologies we included WLAN to the analysis, as it has been identified by the Next Generation Train Control (NGTC) project as a potential candidate for railway communications in urban areas.</p>

Table 4-2: Overview on technology categories



The following table gives the typical data rates achieved by these systems:

Technology	Carrier Bandwidth	Min. Carrier Bandwidth	Data Rate (Min. Carrier Bandwidth)	Max. Carrier Bandwidth	Data Rate (without MIMO /at max. Carrier Bandwidth)
<b>2G Mobile Technologies</b>					
GPRS	200 KHz	200kHz	21.4 kBit/s	200 kHz	171.2 kBit/s
EDGE	200 KHz	200kHz	48 kBit/s	200 kHz	384 kBit/s
<b>3G Mobile Technologies</b>					
CDMA2000	1.25 MHz	1.25 MHz	3.1 Mbit/s		
UMTS with HSPA/HSPA+	5 MHz <sup>2</sup>	5 MHz	26 Mbit/s		
<b>4G Mobile Technologies</b>					
LTE-(Advanced)	1.4-100 MHz	1.4 MHz	0.4-4.0 Mbit/s	20 MHz	6.8-67.9 Mbit/s
WiMAX (Advanced)	1.3-20MHz	1.3 MHz	0.3-3.1 Mbit/s	20 MHz	6.3-63 Mbit/s
<b>PMR Technologies</b>					
DMR	12.5 kHz	12.5 kHz	9.6 kBit/s		
dPMR	6.25 kHz	6.25 kHz	4.8 kBit/s		
NXDN	6.25 kHz	6.25 kHz	4.8 kBit/s		
P25	12.5 kHz	12.5 kHz	9.6 kBit/s		
TETRA	25 kHz	25kHz	7.2 kBit/s	4x25 kHz	28.8 kBit/s
TETRA-TEDS	25-150 kHz	25kHz	66 kBit/s	150 kHz	538 kBit/s
TETRAPOL	12.5 KHz	12.5 KHz	7.2 kBit/s		
<b>Other</b>					
Wi-Fi	20 / 40 MHz	20 MHz	6-60 MBit/s	40 MHz	13.5-135MBit/s

Table 4-3: Overview on main technical parameters

<sup>2</sup> 5 MHz bandwidth for implementation of UMTS with HSPA/HSPA+ would only be possible in countries where both the R-GSM and ER-GSM band are available

Table 4-4 gives an assessment of the different technologies against the primary criteria:

Technology	Carrier bandwidth	Band availability	Support Mobility	Open Standard
<b>2G Mobile Technologies</b>				
GPRS	Yes	Yes	Yes	Yes
EDGE	Yes	Yes	Yes	Yes
<b>3G Mobile Technologies</b>				
CDMA2000	Yes	Yes	Yes	Yes
UMTS with HSPA/HSPA+	<b>No</b> <sup>3</sup>	Yes	Yes	Yes
<b>4G Mobile Technologies</b>				
LTE-(Advanced)	Yes	Yes	Yes	Yes
WiMAX (Advanced)	Yes	<b>No</b>	Yes	Yes
<b>PMR Technologies</b>				
DMR	Yes	Yes	Yes	Yes
dPMR	Yes	<b>No</b>	Yes	Yes
NXDN	Yes	<b>No</b>	Yes	<b>No</b>
P25	Yes	Yes	Yes	Yes
TETRA/TEDS	Yes	Yes	Yes	Yes
TETRAPOL	Yes	<b>No</b>	Yes	<b>No</b>
<b>Other</b>				
Wi-Fi	<b>No</b>	<b>No</b>	Yes	Yes

Table 4-4: Assessment of technologies (Primary criteria)

The following sections give a short discussion of the assessment of the different technologies.

### **2G Mobile Technologies**

The technology table lists the parameters of GSM extensions GPRS and EDGE. These systems are not considered as replacement / extension of the existing GSM-R network but only listed to define the baseline for comparison with the other systems.

### **3G Mobile Technologies**

In this category UMTS and CDMA 2000, two CDMA based technologies, have been considered.

As a result, we believe that UMTS with its extensions HSDPA and HSDPA+ is not a suitable candidate. The minimum required carrier bandwidth is 5 MHz and thus implementations would

<sup>3</sup> 5 MHz bandwidth for implementation of UMTS with HSPA/HSPA+ would only be possible in countries where both the R-GSM and ER-GSM band are available

only be possible in countries where both the R-GSM and ER-GSM band are available. Furthermore, we believe that UMTS is not future proof as with Long Term Evolution (LTE) a successor technology is already on the market that provides higher spectral efficiency. UMTS does currently not provide railway specific services like group calls etc. As these are already under specification for LTE, it is not likely that such features would be developed for UMTS.

CDMA 2000 is widely in use in US and in Asia, in Europe there are only few installations, where UMTS is the dominant 3G technology. CDMA 2000 is standardized by the 3GPP2 (Third Generation Partnership Project 2) and offers the advantage that a version with 1.25 MHz carrier is available that would fit into the target band: CDMA 2000 is available for the 800 MHz Band, supports mobility and is an open standard. With this CDMA 2000 meets all primary criteria. With up to 3.1 Mbit/s CDMA 2000 would provide broadband data rates, nevertheless we do not believe that CDMA 2000 will be used for future railway communications, as we could not identify a clear roadmap for a future evolution of CDMA 2000. The intended 4G successor to CDMA2000 was UMB (Ultra Mobile Broadband); however, UMB was cancelled because its sponsors favoured Long Term Evolution (LTE).

#### **4G Mobile Technologies**

For 4G technologies LTE Advanced (LTE Release 10 and beyond) and WiMAX Advanced have been considered.

LTE Advanced is standardized by the 3GPP (Third Generation Partnership Project) and is seen as evolution of LTE to meet the criteria of ITUs IMT Advanced initiative. LTE is available with channel width from 1.4 to 100 MHz, thus would fit into the target band with a 1.4 MHz carrier. LTE is available for the 800 MHz Band, supports mobility and is an open standard. With this LTE meets all primary criteria. LTE supports QoS. In 1.4 MHz carrier width, data rates of up to 4 Mbit/s are achievable. The implementation of mission critical services like group calls is ongoing. Thus, LTE is definitely a possible candidate technology that also has been identified by the Next Generation Train Control (NGTC) Project.

WiMAX Advanced is an evolution of the WiMAX standard to meet IMT Advanced criteria. WiMAX originally has been developed as point-to-multipoint system for wireless local loop applications and later extended for mobile WiMAX with a different air interface. Mobile WiMAX is available with different carrier widths in a range from 1.3 to 20 MHz. Thus, a carrier for mobile WiMAX would fit in the available spectrum. According to the WiMAX forum that markets the WiMAX standard, WiMAX supports 3, 2.5, and 3.5 GHz bands, 700 MHz and 1.8 GHz are under consideration. With data rates of up to 3.1 Mbit/s in 1.3 MHz, the bandwidth requirements for broadband would be met. There have been installations for mobile WiMAX for example by operator Sprint in major US cities. But this network is shutting down and will be replaced by LTE. There are (have been) also only few handsets been on the market. A query for smartphones on GSMARENA.com did not come up with any recent handsets. However, USB dongles and end user terminals for wireless local loop applications are available. The latest standard documents also only cover carrier bandwidths of 5 MHz and above. Currently no railway specific services like group calls are available or in standardization process.

Thus, in summary we believe that WiMAX is not a probable candidate for replacing GSM-R.

As the spectrum masks of LTE and WiMAX have been aligned (e.g. CEPT Report 40 [1]), it is further anticipated that interference effects from WiMAX on GSM-R and LTE on GSM-R are comparable. Thus if feasibility (or non-feasibility) of sharing from LTE and GSM-R has been found these result could be transferred insofar to WiMAX, as modifications to GSM-R to achieve compatibility with WiMAX are likely to be the same like for LTE, while there might be differences in the degradation of WiMAX performance compared to the ones found during analyses for LTE.

### **PMR Technologies**

A range of PMR technologies has been included to the analysis. The systems DMR, dPMR and NXDN are examples of systems for networks with lower complexity that target to replace analogue PMR implementations. These systems can operate with narrow carrier bandwidth in a range of 6.25 kHz to 12.5 kHz and thus would fit in the target frequency band. However, the data rates provided by these systems do not exceed the rates provided by GSM-R (without GPRS or EDGE) and thus are no suitable replacements for the existing GSM-R Network.

A similar situation is found for the systems TETRA, APCO P25 and TETRAPOL that are used in larger networks, including nationwide networks for public security systems. Also, these systems have narrow carrier bandwidth of 12.5 kHz or 25 kHz, but can provide only limited data rates. TETRA release 2 offers TETRA Enhanced Data Services that allows carrier aggregation in a bandwidth of up to 150 kHz and resulting achievable data rates of approximately 500 kBit/s, which slightly exceeds the data rates available for GSM with EDGE.

However, we believe that the increase in data rate of approximately 100 kBit/s will not justify the rollout of a completely new TETRA network to replace GSM-R, even if the TETRA technology is more recent than GSM (first TETRA products have been available around 1996, TETRA release 2 was approved in 2006). There is also a strong tendency to extend or even replace mission critical TETRA networks with LTE mission critical to provide the bandwidth required by recent applications.

In summary, we therefore believe that TETRA (with TEDS) is not a probable candidate for replacing GSM-R.

### **Other Technologies**

Within this technology group, we analysed Wi-Fi, which is a local area wireless computer networking technology based on the IEEE 802.11 series of standards, and has also been identified by the Next Generation Train Control (NGTC) Project as possible technology for railway communications in urban areas.

However, Wi-Fi is currently only specified with channel width of 20 MHz and 40 MHz and is not available for the 800 MHz frequency band.

We therefore consider Wi-Fi not as a candidate to be studied within the scope defined for this study.

## **4.2 Conclusion**

LTE Advanced is available with channel width from 1.4 to 100 MHz, thus would fit into the target band with a 1.4 MHz carrier. LTE is available for the 800 MHz Band, supports mobility and is an open standard. With this LTE meets all primary criteria. LTE supports QoS. In 1.4 MHz carrier width, data rates of up to 4 Mbit/s are achievable. The implementation of mission critical services like group calls is ongoing. LTE has also been identified by the Next Generation Train Control (NGTC) Project.

As a result of the technology evaluation, we therefore conclude that LTE / LTE Advanced is, currently, the only practical candidate for the future railway system.

## 5 Sharing Analyses

### 5.1 Interference Model

During technology evaluation, "LTE / LTE Advanced" has been identified as a possible candidate for the future railway radio system. The LTE standard defines different carrier bandwidth from 1.4 MHz up to 20 MHz (without carrier aggregation) in both FDD and TDD mode. With 2x4 MHz paired spectrum in the R-GSM band, thus, a 1.4 MHz carrier in FDD mode has been selected for the analysis. Different scenarios of where to place the LTE carrier in the available band are possible:

- LTE carrier either at the lower edge of the R-GSM or ER-GSM band (depending on country specific band availability)
- LTE carrier within the ER/R-GSM band
- LTE carrier at the upper band edge of the R-GSM band (e.g. adjacent to the public 900 MHz band).

Figure 5-1 depicts a scenario, where a 1.4 MHz LTE carrier that is sitting within the R-GSM band:

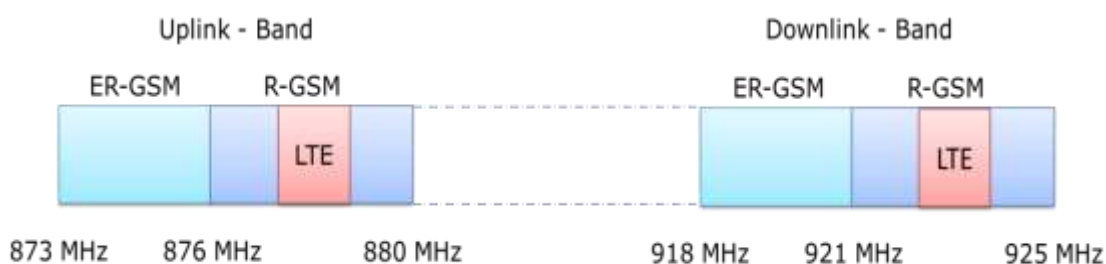

Figure 5-1: 1.4 MHz LTE carrier in R-GSM band

Different aspects need to be considered, depending on the location of the LTE carrier inside the band available for GSM-R:

- LTE at edge of band for GSM-R
  - Only one guard band between LTE and GSM-R is required
  - Impact from and to LTE to services outside the band for GSM-R need to be considered
- LTE somewhere in the band
  - Interference between LTE and GSM-R needs to be considered below and above the LTE carrier, thus two guard bands need to be considered

However, supposing symmetrical spectrum masks for both GSM-R and LTE it is reasonable to assume that the same guard band to protect GSM-R is required irrespective whether the GSM-R carrier is located above or below the LTE carrier. Interference from an individual GSM-R carrier to LTE depends only on the guard band between the carriers, once again irrespective of the GSM-R carrier location above or below the LTE carrier.

Thus the guard band required can be initially determined by analysing a scenario where a GSM-R carrier that is located on one side of the LTE carrier (either above or below).

The model used to perform the analyses consists of the interfered system (wanted transmitter, wanted link and receiver) and the interfering transmitter that affects the transmitter via the interfering link:

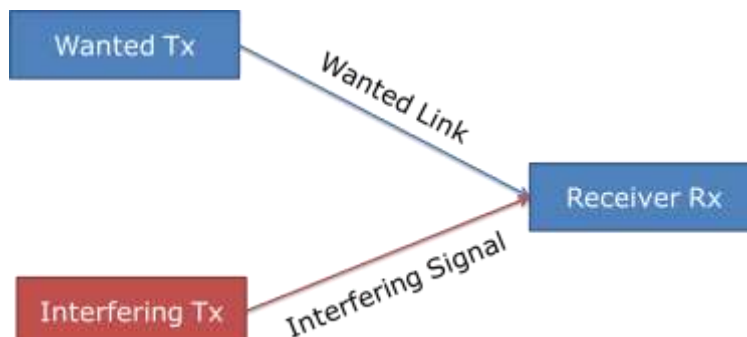

Figure 5-2: Interference model

The following chart depicts the different metrics resulting from this model based on an interference scenario where LTE is interfering with a GSM-R connection:

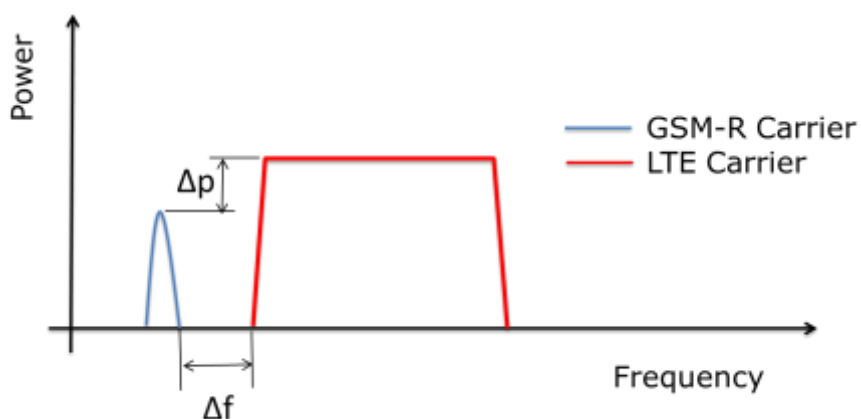

Figure 5-3: Interference scenario

With this model, the impact of the interfering signal generally depends on the following parameters:

- The frequency separation  $\Delta f$  between the wanted signal (GSM-R in the example above) and the interfering signal (LTE in the example above) expressed as guard band between carrier band edges
- The absolute level of wanted signal  $Rx_W$
- The power difference of the wanted and the interfering signal  $\Delta p = Rx_I - Rx_W$
- The characteristics of the transmitted signals (both wanted and interfering signal)
- The characteristics of the receiver as defined in technology standards

If not stated otherwise, the reference points as shown in Figure 5-4 have been used in the calculations:

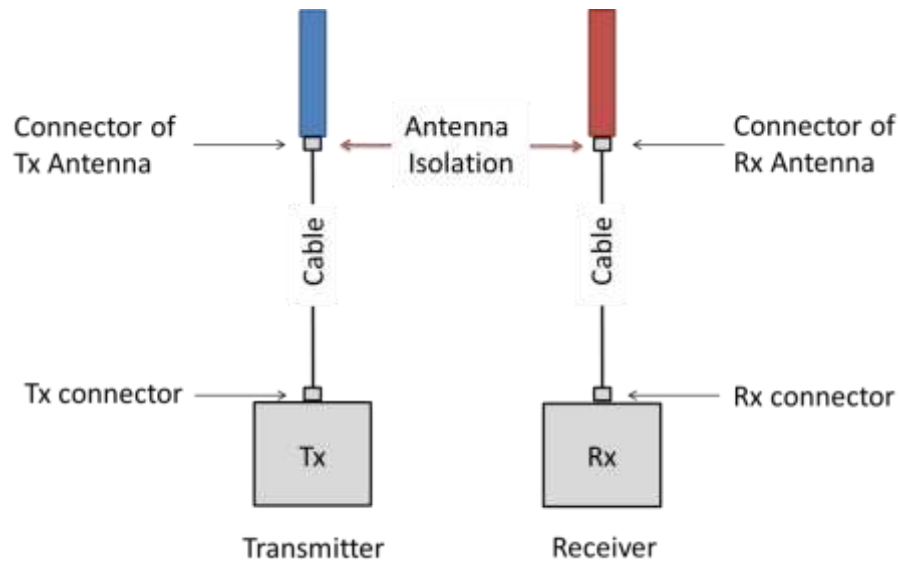

Figure 5-4: Reference points for calculations

With this nomenclature, the following applies:

- Transmitting systems are defined by their transmit power and additional characteristics like spectrum masks, out-of-band emissions etc. at the Tx connector of the transmitter
- Receiving systems are characterized by parameter like their receive sensitivity, blocking characteristics etc. at the Rx connector of the receiver.
- Antenna characteristics including antenna installation (e.g. mounting heights, orientation and distance between Rx and Tx antennas) and propagation between antennas are included in the antenna isolation that is defined between the connectors of the Tx and Rx antenna.

Taking the interference model from above into account in total eight different interference relations need to be analysed: Four relations where GSM-R is victim of interference from LTE, and four relations where LTE is interfered by GSM-R. Taking further into account that both systems will use frequency division duplex (FDD) with a duplex separation of 45 MHz between uplink and downlink and assuming a frequency separation of  $\Delta f$  between the LTE and the GSM-R carriers band edge, the following minimum frequency separations need to be considered in the interference analysis:

		Interferer				
		GSM-R		LTE		
		BTS	MS	BTS	UE	
Victim	GSM-R	BTS	-	-	$45 \text{ MHz} + \Delta f$	$\Delta f$
		MS	-	-	$\Delta f$	$45 \text{ MHz} - \Delta f$
	LTE	BTS	$45 \text{ MHz} - \Delta f$	$\Delta f$	-	-
		UE	$\Delta f$	$45 \text{ MHz} + \Delta f$	-	-

Table 5-1: Minimum frequency separation for interference scenarios

The table shows two general ranges for the frequency separations: A rather large frequency separation in the range of the duplex separation of 45 MHz (more precisely of  $45 \text{ MHz} + \Delta f$  or  $45 \text{ MHz} - \Delta f$ ) in cases where a BTS interferes another BTS, or where a UE interferes with another UE, and a frequency separation of  $\Delta f$  for interference of BTS to UE or UE to BTS.

Thus, different approaches need to be analysed to consider the different frequency separations.

## 5.2 Determination of Antenna Isolation for different Implementation Scenarios

For the purpose of this study, antenna isolation will be defined as isolation between the connectors of the antennas for the systems analysed (see Figure 5-4 on page 39). The antenna isolation thus includes effects of the antenna pattern and the path loss due to wave propagation between the antennas.

For calculation of the path loss between antennas a combination of free space loss and a path loss based on the Okumura-Hata equation has been used. To consider the worst case the Okumura-Hata extension for rural areas has been employed.

For distances up to approximately 500 m free space loss has been assumed, in a range from 500 m to 1000 m a transition function has been used while for larger distances the Okumura-Hata equation for open areas has been applied.

Antenna isolations have been determined for the following general scenarios:

- Site-to-Site
- Train-to-Train
- Site-to-Train

The results are detailed in the following sections.

### 5.2.1 Site-to-Site Scenarios

Site to site scenarios cover the following three sub-scenarios:

- LTE and GSM-R BTS are using the same antenna on the same site
- LTE and GSM-R BTS are sharing the same site but uses individual antennas
- LTE and GSM-R BTS antennas are using different sites, however these sites are located in the same area

In any of these cases interference will be from a BTS to BTS and thus the minimum frequency separation between the systems will be the duplex separation of 45 MHz +/- the frequency separation  $\Delta f$  of the two carriers.

#### 5.2.1.1 Site-to-Site (Same Site, same Antenna)

Instead of using individual antennas for LTE and GSM-R, the use of one antenna for both systems could be considered. In this case a coupling network is required that on the one hand couples both signals with a minimum loss to the antenna, and on the other hand ensures that a high isolation between the LTE and the GSM-R system is achieved:



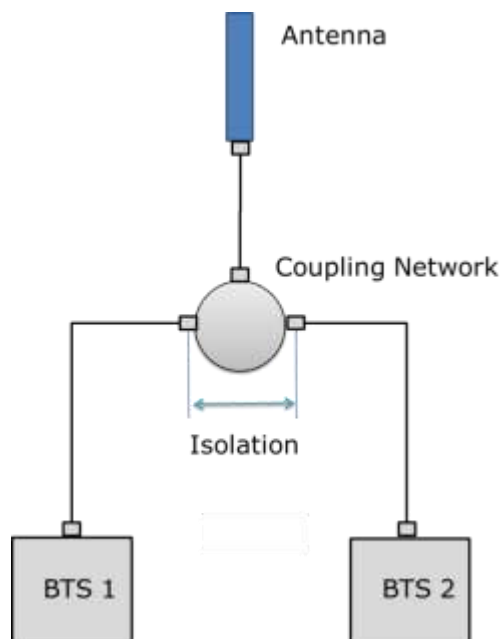

Figure 5-5: Use of same antenna by two BTS

In this scenario, the antenna isolation is replaced by the isolation between the connector ports of the coupling network.

Coupling networks (often called in-band, band-sharing or same-band combiner) to use the same antenna for different BTS in the same band (e.g. GSM and LTE or UMTS in the 900 MHz GSM band) are available off-the-shelf from different vendors. Relevant parameters of in-band combiner for the scope of this study are:

- The minimum required guard band between the two systems
- The achievable Tx – Rx isolation
- The relevant insertion losses

The following table gives an overview on characteristics of two in-band combiners available for the 900 MHz band on the market today. More combiners addressing the same purpose have been found. However, as the available datasheets did not identify the required guard bands, the parameters have not been included to the table:

Type	Use	Required Guard Band	Isolation	Insertion Loss
Kathrein 78210931	GSM <-> LTE GSM <-> UMTS	3 MHz	30 dB	0.6 dB
CCi PFC-900-X	GSM <-> UMTS GSM <-> GSM	500 KHz 1 MHz	60 dB	Tx:1.2 dB Rx: 0.8 dB

Figure 5-6: Characteristics of some in-band combiner

The table shows that some filter solutions exists, however the coupling networks are always a compromise between required guard band, isolation and insertion loss. The required guard bands are also relatively large given the small size of the ER/R-GSM band and may unnecessarily reduce the amount of spectrum that can be effectively used.

The analysis of achievable antenna isolations with vertically separated antennas mounted on the same tower (section 5.2.1.2) further shows that with a vertical distance of antennas of 1 m antenna isolations in a range of 45 to 60 dB can be achieved without adding a separate insertion loss, nor is a specific frequency separation required. We therefore anticipate that the use of in-band combiners would likely be limited to a few, specific cases.

### 5.2.1.2 Site-to-Site (Same Site, individual Antennas)

Analyses of antenna isolation for installations, where the same site is shared by two radio systems has been done in report ITU-R M. 2244 "Isolation between antennas of IMT base stations in the land mobile service" [9]. This report gives calculations to determine the antenna isolation dependent on the vertical and horizontal antenna separation. In addition, it details measurement results for different frequency ranges and antenna constellations.

The given equations are only applicable if the following requirements are met:

- Vertical distance between antennas is larger than  $10 \times$  wavelength
- Horizontal distance of antennas is larger than  $2 \times D^2 / \text{wavelength}$  where D is the largest dimension of the antenna.

The lowest frequency in the ER-GSM band is 873 MHz with a corresponding wavelength of approximately 34 cm. With a typical antenna size of 1 m for GSM-R antennas a minimum horizontal distance of approximately 5.8 m and a minimum distance of 3.4 m for vertical antenna separation is found before the equations can be used.

Therefore, the equations have only limited applicability for our analysis of railway systems where very often radio towers are used along the tracks and therefore the antennas need to be installed very close to each other on the same mast:

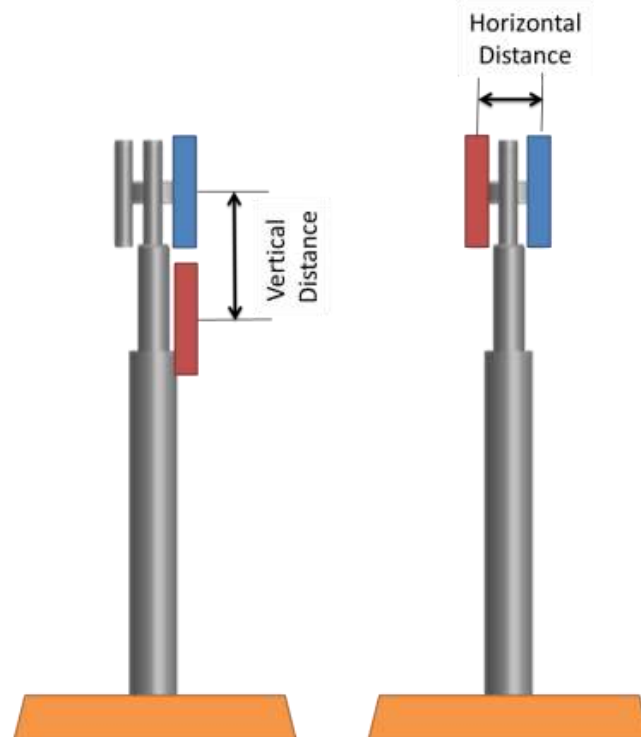

Figure 5-7: Typical site-sharing scenarios (vertical separation left, horizontal separation right)

Aside the analytical approach the report also gives measurement results for antenna isolations for installations with different vertical separations at a frequency range of 890 MHz. The measurements have been done for the following polarizations:

- Vertical polarization vs. vertical polarization
- Vertical polarization vs. 45° polarization
- In-phase 45° polarization
- Orthogonal 45° polarization

Figure 5-8 summarizes the results of the measurements. The blue dots give measurement results; the red line shows antenna isolations as calculated with the equation given for vertical separation. Please note that the measurement results show for same vertical distances some variations as the values measured for different polarizations have been displayed at the same time:

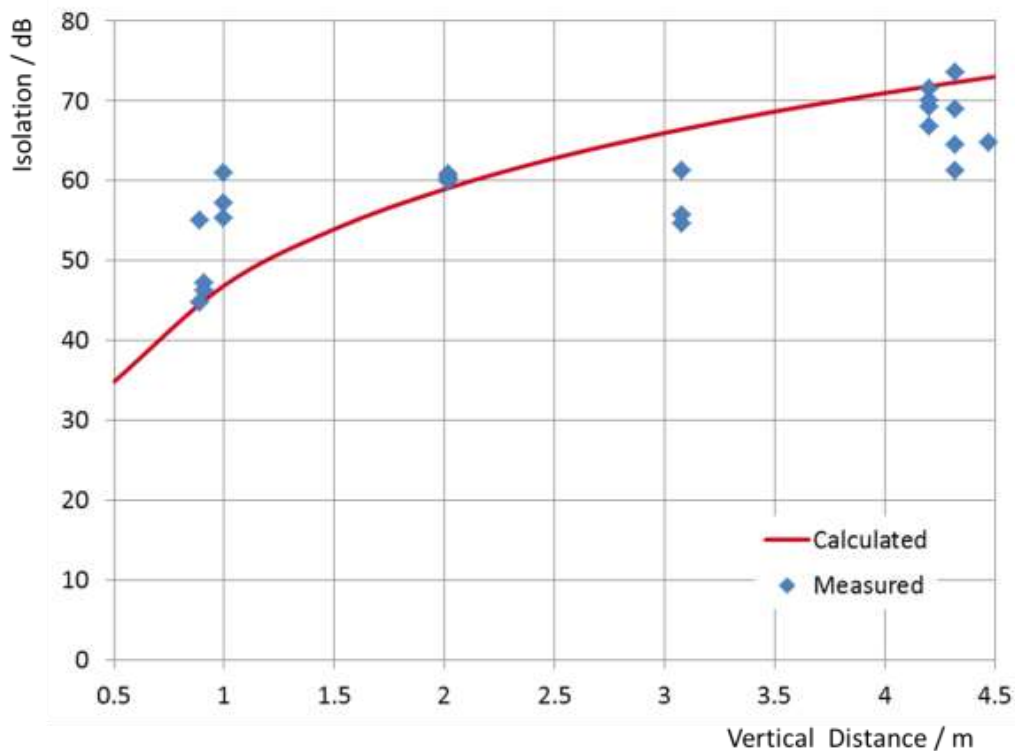

Figure 5-8: Antenna isolation (on-site) different vertical distances (source ITU-R M.2244 [9])

A comparison of the measurements with the calculations further shows that for small antenna separations the calculated antenna isolation is smaller than measured, while for larger vertical distances the measured values are smaller than the calculated once. This might be due to coupling effects along the tower that are not considered in the calculation.

Depending on the mast height, reasonably achievable vertical antenna distances are in a range of 1 to 3 m resulting in antenna isolations in a range from 45 to 65 dB.

### 5.2.1.3 Site to Site (Individual Sites)

Figure 5-9 depicts the Site-to-Site scenario where different sites are used (general view left, top view right):

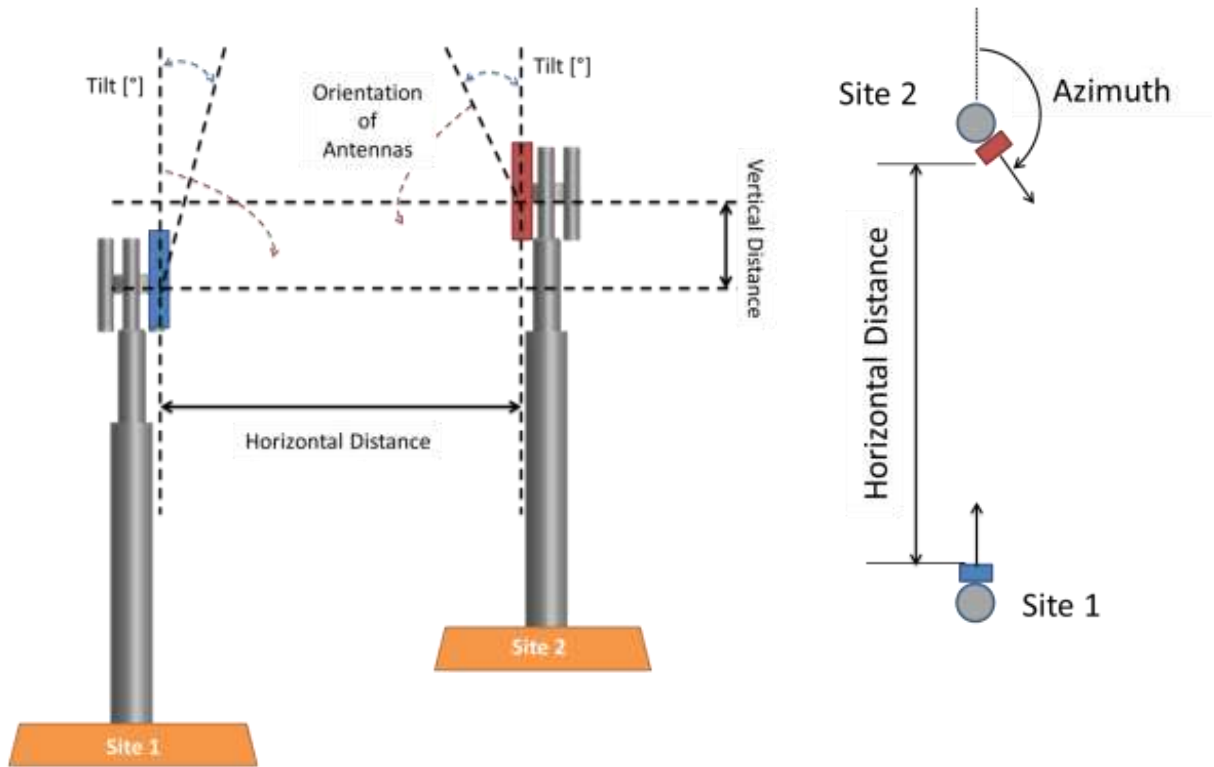

Figure 5-9: Site-to-Site scenario

The antenna isolation between Site 1 and Site 2 depends on the used antennas, the horizontal and vertical distance between antennas and the orientation of the antennas (azimuth and tilt). For the calculations, the antenna pattern of a typical antenna (Kathrein 80010141) has been considered:

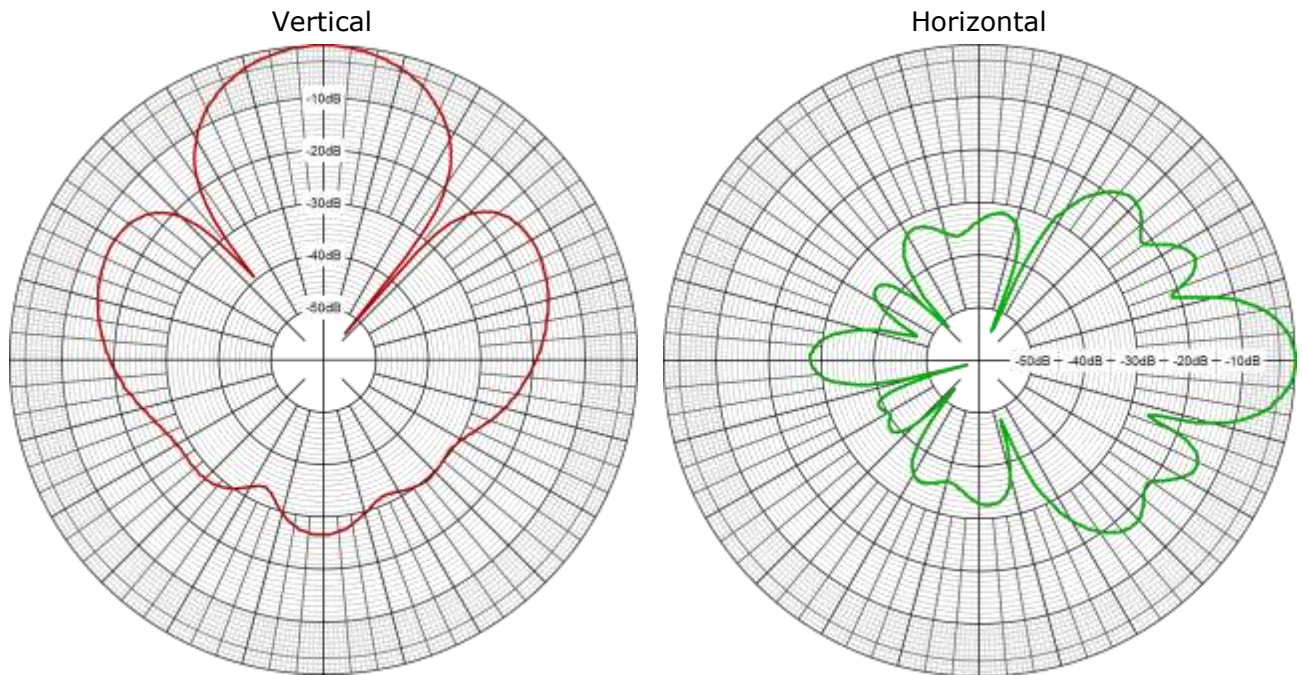

Figure 5-10: Base Station antenna pattern (Kathrein 80010141)

Talking into account that the antenna isolation depends on the relative orientation of antennas to each other and will reach a minimum when the antennas directly face each other the parameter range has been narrowed down to the values as show in the following table:

Parameter	TX Site	RX site
Antenna Type	Kathrein 80010141	Kathrein 80010141
Antenna Tilt	0°	0°, 4°, 6°, 8°, 10°
Antenna Azimuth	0°	120° - 180° increment (10°)
Horizontal Separation	up to 5000 m	
Vertical Separation	+5 m, 0 m, -5 m to -22 m (in reference to Tx site)	

Figure 5-11: Parameter range for Site-to-Site calculations

The following picture shows the resulting isolation over distance for a variation of vertical separation with antenna tilts of 0° and azimuth of 180° for site 2, thus both antennas are facing each other if the height separation is zero:

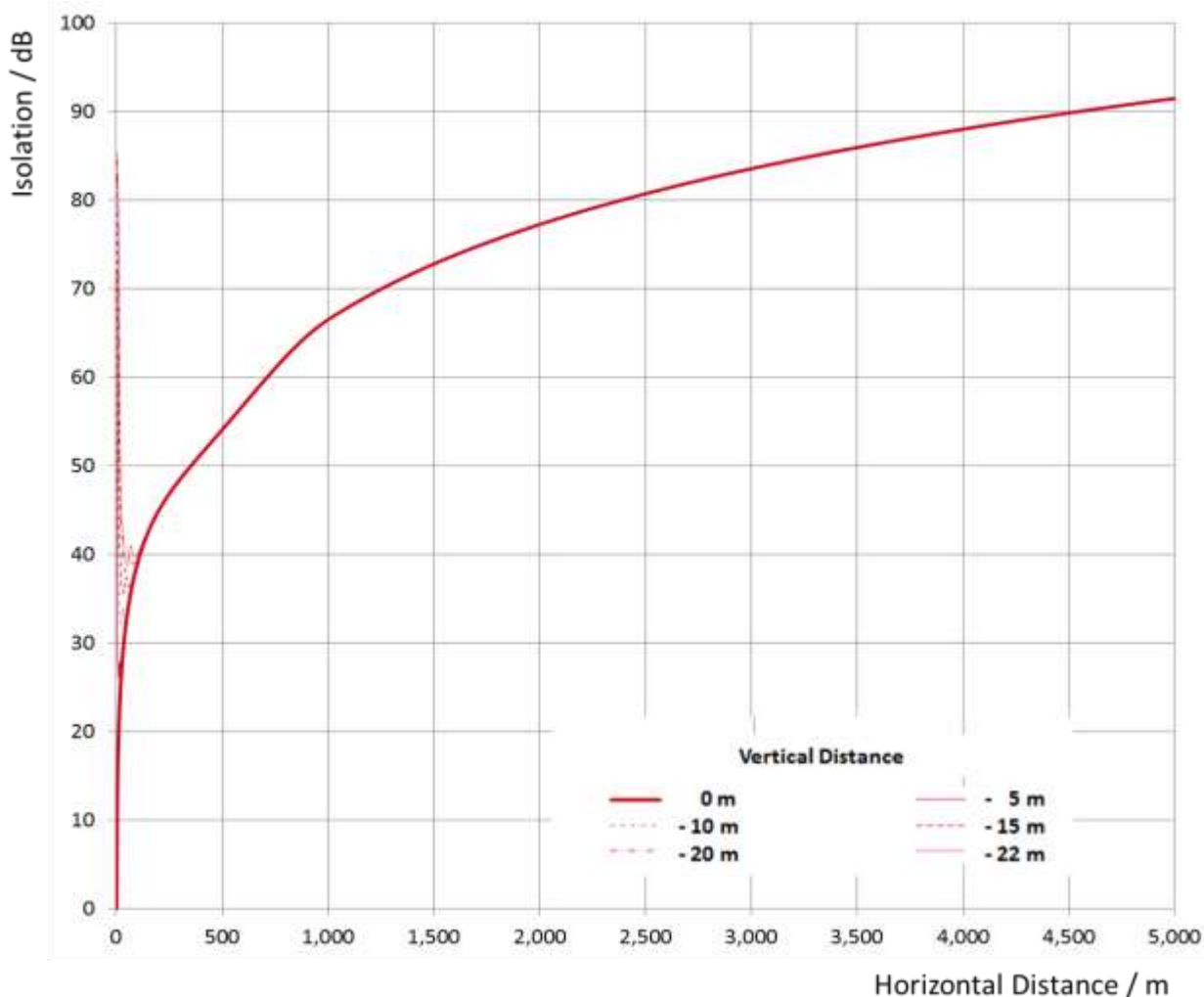

Figure 5-12: Antenna isolation over site-to-site distance for different vertical distances

The figure shows that for site-to-site distances above approximately 100 m the antenna isolation is the same, independent from the vertical antenna distance. Figure 5-13 shows the same curves for horizontal distances up to 250 m:

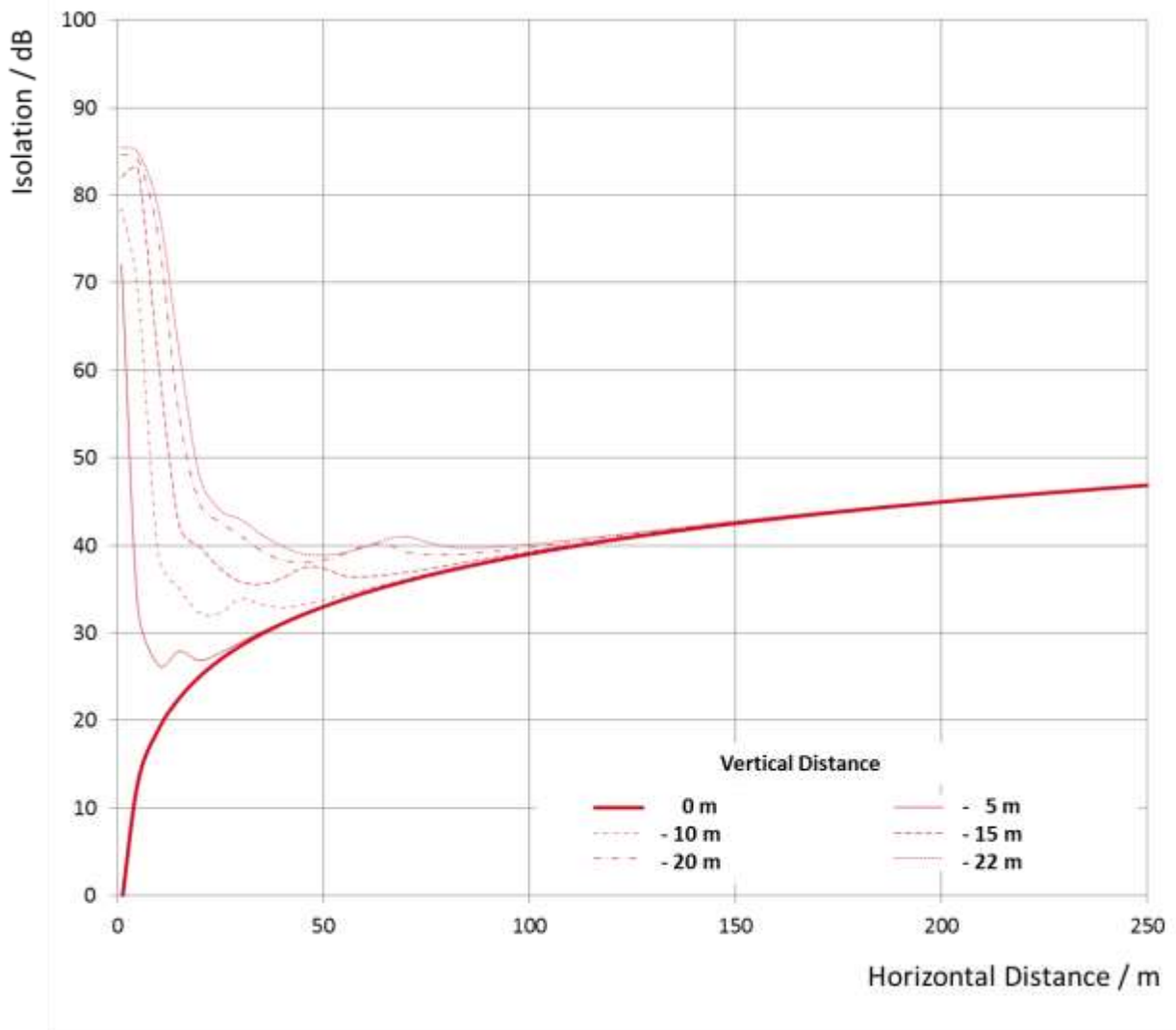

Figure 5-13: Antenna isolation over site-to-site distance for different vertical distances

The chart shows that the isolation increases when the antennas are not mounted at the same height and, in consequence, are not directly pointing to each other.

In conclusion, it can be said that the antenna isolation can become critical if the antennas are oriented to each other. In such a scenario, considerable distances above 200 m between sites are required to achieve the required isolation.

### 5.2.2 Site-to-Train Scenarios

For the purpose of the calculation of antenna isolations between a BTS and the train, it has been assumed that the train moves on a straight line passing the BTS in a specific distance. Figure 5-14 depicts the geometrics of the analysed Site-to-Train scenario:

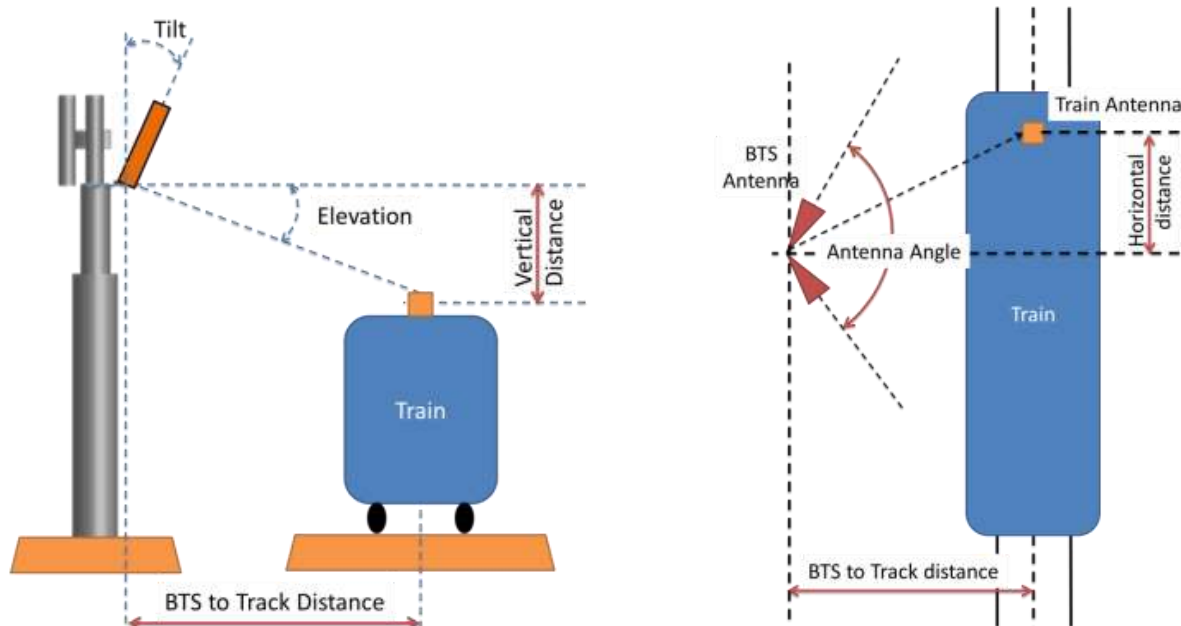

Figure 5-14: Site-to-Train scenario (Side view left, top view right)

For the BTS antennas, it has been assumed that two antennas of same type are mounted at the same heights. The relative orientation of the antennas is described by the antenna angle; it has been further assumed that the antenna orientation is symmetrical to the track, such an antenna angle of 180° means that the boresights of the antennas are parallel to the track.

The following table gives the parameter range that has been used for the different calculations:

Parameter	Value
BTS Antenna Type	2 x Kathrein 80010141
BTS Antenna Angle	160°, 175°, 179°
BTS Antenna Height	15 m, 20 m, 25 m, 30 m
BTS Antenna Tilt	0°, 1°, 2°, 4°, 8°
BTS to Track Distance	3 m, 5 m, 10 m
Train Antenna Type	Kathrein K702061
Train Antenna Height	4 m
Horizontal Distance	-400 m to +400 m

Figure 5-15: Parameter range for site-to-train calculations

Figure 5-16 depicts the antenna isolation between BTS and train for different antenna heights, a BTS antenna azimuth of 179° and 8° down tilt:



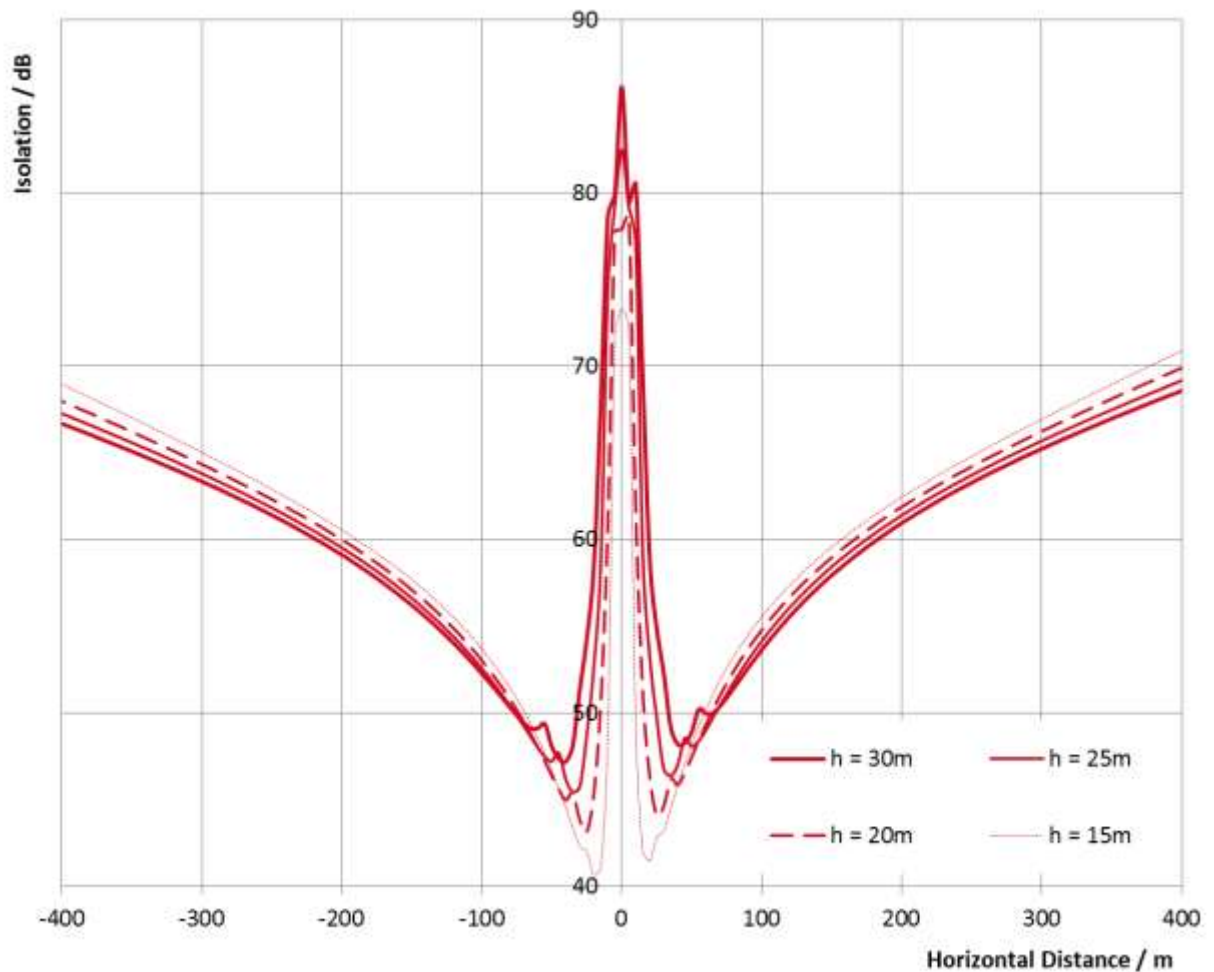

Figure 5-16: Antenna isolation BTS-to-train over BTS-to-train distance for different BTS antenna heights.

It is found that the antenna isolation between the BTS and the train can go down to approximately 40 dB in cases where the BTS antenna is mounted at heights below 20 m and is using down tilt.

### 5.2.3 Train-to-Train Scenarios

Train-to-Train scenarios cover the following three sub-scenarios:

- LTE and GSM-R MS use the same antenna (on the same train)
- LTE and GSM-R MS use individual antennas (on the same train)
- LTE and GSM-R MS between different trains.

The second and third sub-scenario are comparable and are thus both treated in section 5.2.3.1.

In any of these cases interference will be from a UE to a UE and thus the minimum frequency separation between the systems will be the duplex separation of 45 MHz +/- the frequency separation  $\Delta f$  of the two carriers.

---

### 5.2.3.1 Use of same Antennas for LTE and GSM-R

In section 5.2.1.1, the use of the same antenna for both GSM-R and LTE has been discussed for the case of base stations. It has been found that coupling networks exist that can be used to combine the two systems, however at the price of a specific insertion loss and the requirement of a specific guard band.

A similar concept could be used for trains. During our web research, we could not identify any available off-the shelf solution for in-band combiners to be used at the mobile station. However as such solutions exist for base stations we believe that it would be technical feasible to produce such equipment as well for mobile station if required. However, there are some additional constraints that apply to mobile station:

- BTS for GSM are using pre-assigned frequencies and, thus, the coupling network could be adjusted to the frequencies assigned to the BTS while frequencies used at the mobile station changes with the cells. Therefore, the use of such in-band combiners could, on the one hand, become more complicated than in the case for base stations, or would limit the mobile station to a sub-band of available GSM (or LTE) carriers which could cause problems when different channel assignments are used in different parts of the network (or when the train is passing a national border).
- Depending of the type of the coupling network a considerable insertion loss is introduced between antenna and the mobile station. While at base stations this could be compensated by the higher available transmit powers and receive sensitivities this could likely not be accepted at the mobile station side where transmit powers are typically fixed and the receive sensitivities are comparable low in comparison to the base stations. The link budget calculations in section 9.4.2 furthermore showed that the LTE system is likely limited in uplink due to the mobile station transmit power of 21 dBm.

In summary we therefore anticipate that use of in-band combiner at trains is unlikely, as long as not an increase in transmit power for the LTE UE would be foreseen.

### 5.2.3.2 Use of different Antennas for LTE and GSM-R

The train-to-train scenario considers interference between two mobile stations either installed on the same train or on different trains that are passing each other. The following chart shows the antenna pattern of a typical train antenna (Kathrein K702061):

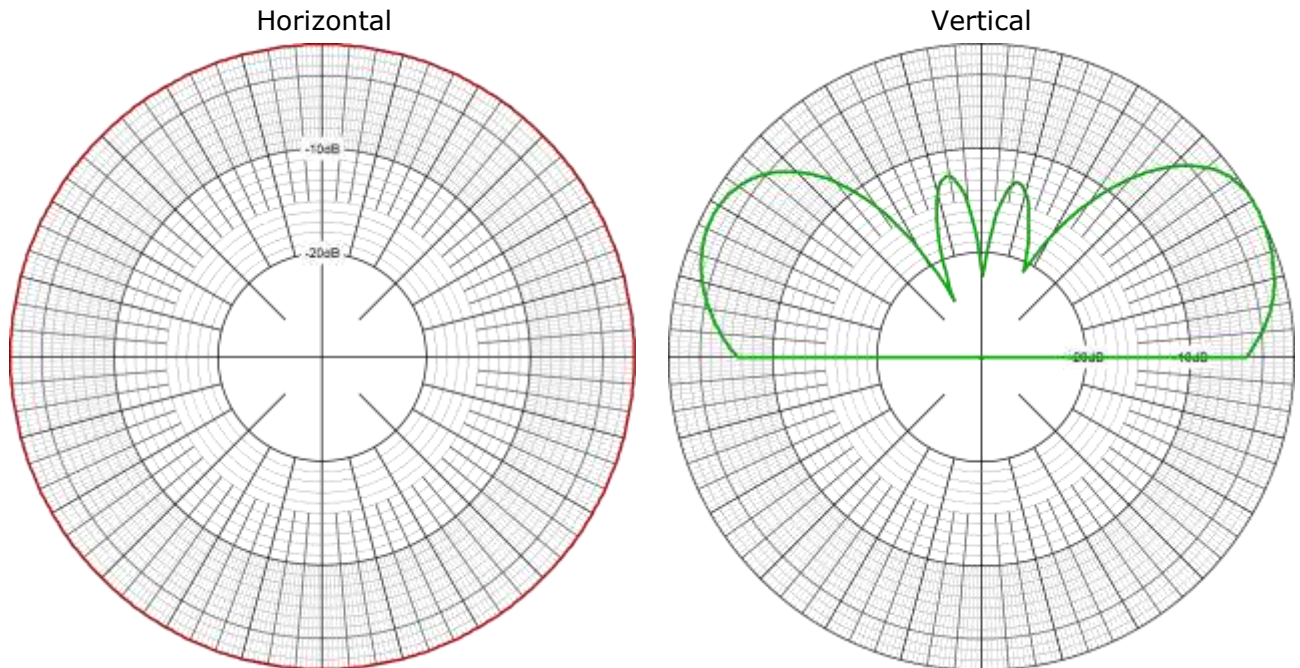

Figure 5-17: Pattern of train antenna (Kathrein K702061)

The horizontal pattern is omnidirectional, thus the horizontal orientation of the antennas (or the trains) is not important for the calculation. The vertical pattern shows a maximum gain of 5.15 dBi at a vertical angle of approximately 27°. It has been reduced to the upper part of the diagram as the lower part is shaded by the train. It is therefore anticipated that the worst case is found if the two antennas are mounted at the same height as in any other case the shadowing by the engine at the higher located train would add additional loss that increases the antenna isolation.

With this, constant antenna gains of 0.5 dBi applies to the calculation and the variation in antenna isolation depends only on the vertical distance between the antennas:

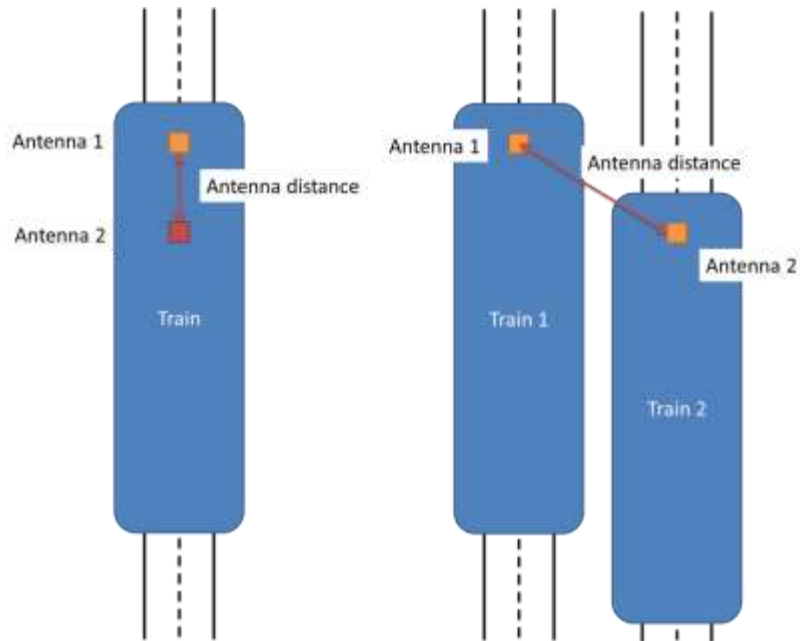

Figure 5-18: Train-to-train scenario: Antennas on same train (left) and on different trains (right)

Figure 5-19 shows the resulting antenna separation for distances in a range from 1 m to 20 m:

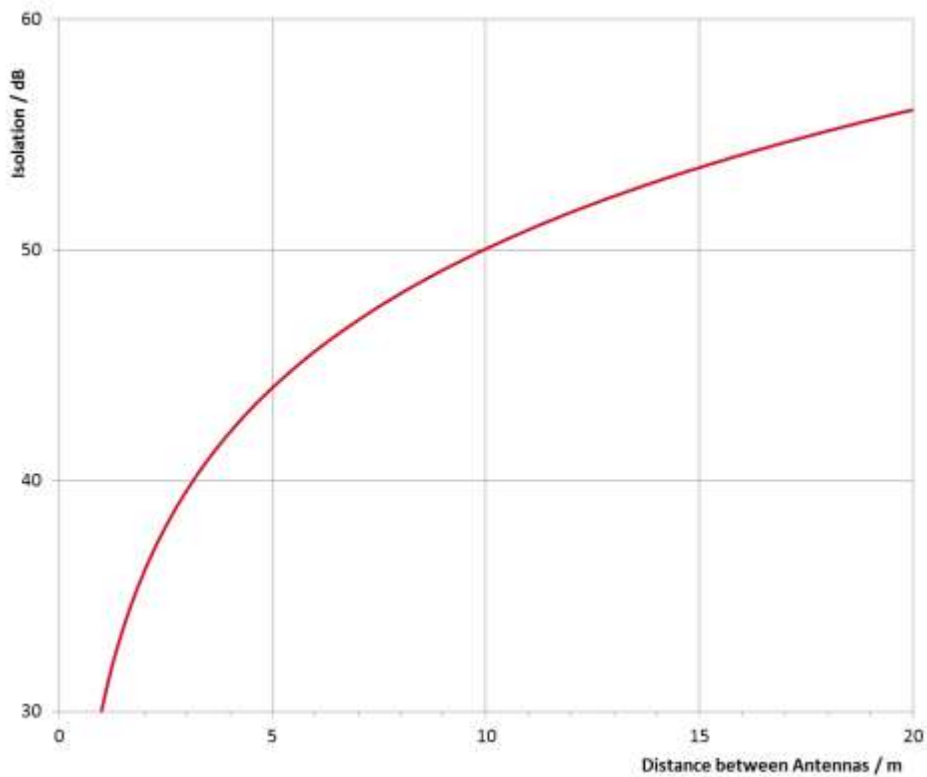

Figure 5-19: Antenna isolation train-to-train

Considering that typical minimum distances between track centres of parallel lines are in a range of 3.2 to 4.5 m, it is found that the isolation is in a range of approximately 40 dB. However, if the antennas are not located at the centre line of the train distances could go down in worst case to approximately 1 m with a resulting antenna isolation of approximately 30 dB, which would likely be the worst case for train-to-train antenna isolation.

### 5.2.4 Summary on Antenna Isolation Calculations

The analysis of achievable antenna isolations has been done for different scenarios and different parameter ranges. The following table gives the range for minimum values of antenna isolations found from the calculations:

Scenario	Antenna Isolation	Comment
Site-to-Site <i>Same Site</i> <i>Same Antenna</i>	30 dB to 60 dB	Isolation depends on used in-band combiner. A combiner dependant frequency separation might be required; the combiner further will add additional insertion losses.
Site-to-Site <i>Same Site</i> <i>Individual Antennas</i>	45 dB to 65 dB	The value of 45 dB corresponds to an antenna separation of approximately 1 m.
Site-to-Site <i>Different Sites</i>	45 dB	Dependant on site distance and antenna orientation. 45 dB corresponds to a distance of approximately 200 m with antennas facing each other.
Site-to-Train	40 dB to 45 dB	Minimum value is found for BTS antenna heights of 15 m. 45 dB corresponds to BTS antenna heights of 20 m.
Train-to-Train	30 dB to 45 dB	Minimum value of 30 dB corresponds to two trains passing each other. 45 dB is achieved if antenna separation is approximately 5 m.

Table 5-2: Results from analysis of antenna isolations

The analysis shows that achievable minimum isolations to be expected in the different scenarios are in a range from 30 dB up to 45 dB.

The minimum values of 30 dB have been found for the "Site-to-Site" scenario using the same antenna for both systems via an in-band combiner. As these combiners typically require a guard band in the range of several 100 kHz up to several MHz this scenario has not been further considered. With this a minimum antenna isolation of 45 dB for the "Site-to-Site" scenario has been found.

The minimum antenna isolation for the "Site-to-Train" scenario is mainly dependant from the BTS antenna height. With 15 m, an isolation of approximately 40 dB is found if the train is located at a specific spot on the track. However, with increasing antenna heights or right outside the critical spot, the isolation quickly raises above 45 dB.

The critical value of 30 dB for "Train-to-Train" antenna isolations has been found for two trains passing each other, where antennas are located at the site of the train.

Therefore, a common value of 45 dB for "Site-to-Site" and "Site-to-Train" scenarios and a minimum value of 30 dB for "Train-to-Train" scenarios have been used in the further analysis.

## 5.3 Analysis: GSM-R interfered by LTE

### 5.3.1 Methodology

Due to the different relevant frequency separations for interference relations between MS – BTS, BTS-BTS and MS-UE different methodologies have been used to assess the interference.

#### BTS-to-BTS and UE-to-MS Interference

BTS-to-BTS and UE-to-MS interference are characterized by a frequency separation of approximately 45 MHz between the LTE and the GSM-R signals. Thus, the following effects have been considered:

- Desensitization of the GSM-R BTS (MS) due to spurious emissions of the LTE BTS (UE)
- Out-of-band blocking effects

#### BTS to MS and MS to BTS interference

These interference relations are characterized by a small frequency separation  $\Delta f$  between the LTE and the GSM-R signals. The impact has thus been analysed by calculating and assessing the interference power falling from the interfering LTE carrier into the GSM-R receive band. Calculations have been performed for guard bands  $\Delta f$  of 200, 400 and 600 kHz.

For this in-band and out-of-band emissions from the LTE interfering signal falling into the GSM-R receiver have been weighted by the GSM-R adjacent channel selectivity (ACS) and integrated over the corresponding receive bandwidth using the same method as employed in CEPT Report 40. The following picture and table shows an example of the calculation performed for a scenario with  $\Delta f = 200$  kHz and a LTE carrier located above the GSM-R Signal:

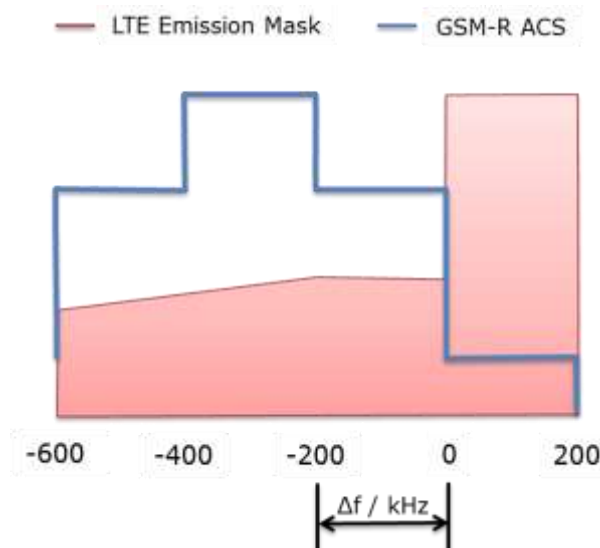

Figure 5-20: Overlap of LTE emission mask and GSM-R ACS for  $\Delta f = 200$  kHz

Separation from LTE Band Edge in kHz	LTE Power in Band in dBm	GSM ACS in dB	Resulting Power in dBm	Resulting Power in mW
0 to 200	34.54902	50	-15.4509804	0.028503747
-200 to 0 kHz	8.761076	18	-9.23892426	0.119153711
-400 to -200 kHz	-5.667409	0	-5.66740858	0.271180927
-600 to -400 kHz	-8.667409	18	-26.6674086	0.002154067
Total Interfering Power in mW				0.420992453
Total Interfering Power in dBm				-3.7572569

Table 5-3: Calculation of LTE interfering power for  $\Delta f = 200$  kHz

In addition to the calculation of in band interfering power, also blocking has been considered as according to the isolation calculations in Section 5.2 rather small antenna isolations and thus comparable high receive levels for interfering signals at the GSM-R BTS and the interfering LTE BTS could occur.

### 5.3.2 GSM-R Downlink: GSM-R MS interfered by LTE BTS

#### GSM-R Downlink: Scenario Description

The following picture illustrates the two different cases for interference from a LTE BTS to a GSM-R MS in downlink. The left picture shows the case for use of different sites for LTE and GSM-R, the right picture the use of the same site:

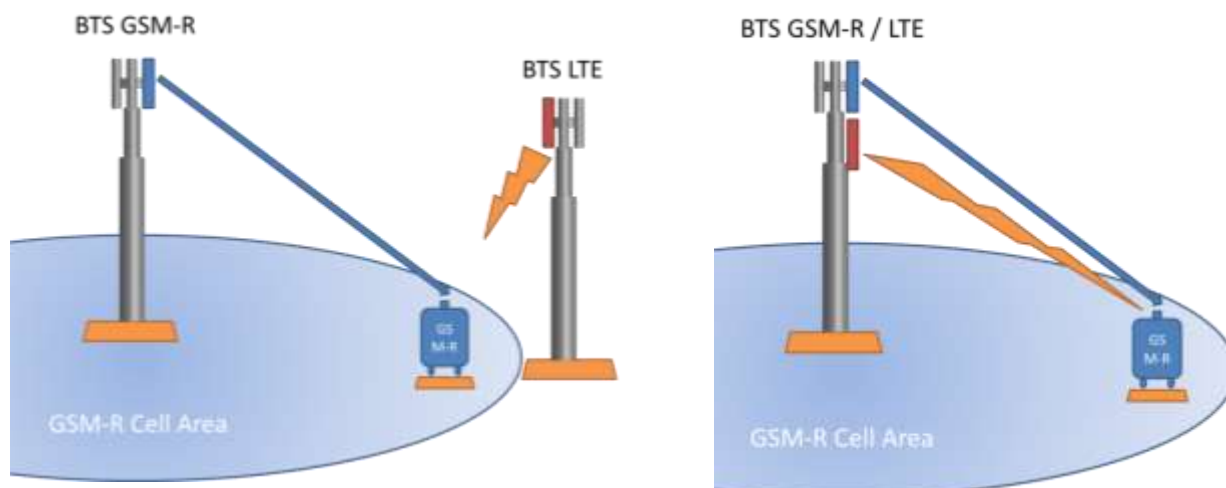

Figure 5-21: Critical scenarios for interference from LTE BTS on GSM-R Downlink

The worst case for separate BTS is found when the interfered MS is at the cell edge of the GSM-R cell and thus receives the GSM-R signal at very low levels while, at the same time, it is very close to a LTE BTS and thus the interfering power is rather high.

In case where both systems use the same site, a comparable path loss for both signals can be assumed if the antennas are at similar height and use similar antenna configurations. This is a

reasonable assumption for sites that intend to cover the same track with both systems. Under this assumption the difference in receive level does not change over distance.

The scenario specific parameters for these two cases are given in Table 5-4:

Scenario	Critical Case	Limiting Parameter	Critical Value	Source
Individual Sites	Receiving GSM-R MS is located at cell edge Interfering LTE BTS is located in close proximity to receiving GSM-R MS	GSM-R MS receive sensitivity at MS Rx connector	-104 dBm	3GPP TS 45.005 Section 6.2
		GSM-R MS reference interference levels	Frequency dependent	3GPP TS 45.005 Section 6.3
		GSM-R MS in-band blocking criteria	-38 dBm	3GPP TS 45.005 Section 5.1
		LTE BTS maximum transmit power at BTS Tx connector	43 dBm	Typical Value Link budget in section 9.4.2
		LTE BTS operating band unwanted emission limits	Frequency dependent	ETSI EN 301 908-14 Table 4.2.2.2.1-1
		Antenna isolation between LTE BTS and GSM-R MS	45 dB	Section 5.2.2
Same Sites	No specific case	Difference in receive levels is mainly dominated by difference in LTE and GSM-R BTS EIRP.		

Table 5-4: Scenario specific parameter for interference from LTE BTS to GSM-R MS



### **GSM-R Downlink: Assessment of in-band interfering Power**

Table 5-5 shows the resulting C/I for the worst case scenario where individual sites are used for LTE BTS and GSM-R BTS:

<b>Parameter</b>	<b>Value</b>			<b>Unit</b>
Guard band	200	400	600	kHz
LTE interfering power in GSM-R channel at LTE BTS Tx connector	-3.76	-8.50	-11.50	dBm
Cable and coupling losses at LTE BTS	6	6	6	dB
Antenna isolation	45	45	45	dB
Max interfering power at connector of GSM-R MS antenna	-54.76	-59.50	-62.50	dBm
Min required level at GSM-R MS Rx connector	-104	-104	-104	dBm
Cable loss at GSM-R MS	3	3	3	dB
Min wanted power at connector of GSM-R MS antenna	-101	-101	-101	dBm
Resulting C/I	-46.24	-41.50	-38.50	dB
GSM-R C/I requirement	9	9	9	dB
Margin	-55.24	-50.50	-47.50	dB

Table 5-5: Assessment of interference from LTE BTS on GSM-R MS using individual sites

The following table shows the calculation for the case where the LTE BTS and the GSM-R BTS share the same site:

<b>Parameter</b>	<b>Value</b>			<b>Unit</b>
Guard Band	200	400	600	kHz
LTE interfering power in GSM-R channel at LTE BTS Tx connector	-3.76	-8.50	-11.50	dBm
Cable and coupling losses at LTE BTS	6	6	6	dB
Antenna gain at LTE BTS	18	18	18	dB
EIRP of transmitted interfering power	8.24	3.50	0.50	dBm
GSM-R transmit power at GSM-R BTS Tx connector	44	44	44	dBm
Cable and coupling losses at GSM-R BTS	6	6	6	dB
Antenna gain at GSM-R BTS	18	18	18	dB
EIRP of GSM-R signal	56	56	56	dBm
Resulting C/I	47.76	52.50	55.50	dB
GSM-R C/I requirement	9	9	9	dB
Margin	38.76	43.50	46.50	dB

Table 5-6: Assessment of interference from LTE BTS on GSM-R using the same site for LTE and GSM-R

Comparing Table 5-5 with Table 5-6 shows that the scenario where GSM-R and LTE use the same site is the less critical case, as due to the similar propagation conditions of both signals, the wanted signal is, even for a guard band  $\Delta f = 200$  kHz, approximately 47 dB higher than the interfering LTE power, leaving a margin of more than 38 dB before the GSM-R MS would be interfered by the LTE signal. Increasing the guard band would further increase the margin.

A different situation is found in case where individual sites for LTE and GSM-R are used (Table 5-5). Under worst case assumptions, the interfering LTE BTS is located in close proximity of the receiving GSM-BTS and the wanted GSM-R MS is at the cell border. The in-band interfering power from LTE might, in this situation, be more than 46 dB higher than the wanted GSM-R signal and, thus, would definitely cause interference. Increasing the guard band would decrease the interfering signal, but not in the required extent to achieve un-interfered operation of the GSM-R system. Thus, the out-of-band emission of the LTE BTS would need to be reduced by at least 55 dB either by ensuing sufficient distance between LTE BTS and GSM-R MS or by adding additional filtering at the LTE BTS to make the scenario with individual sites feasible.

### **GSM-R Downlink: Assessment of Blocking Effects**

According to the isolation calculations in Section 5.2, rather small antenna isolations and thus comparable high receive levels from both the GSM-R BTS and the interfering LTE BTS could occur. This could result in blocking effects at the GSM-R MS. Table 5-7 shows calculations to determine the corresponding LTE blocking power (applicable to both scenarios):

Parameter	Value	Unit
LTE Tx power at LTE BTS Tx connector	43	dBm
Cable and coupling losses at LTE BTS	6	dB
LTE Tx power at antenna connector of LTE BTS antenna	37	dBm
Antenna isolation	45	dBm
LTE blocking power at connector of GSM-R MS antenna	-8	dBm
Cable and coupling losses at GSM-R MS	3	dB
Blocking power at GSM-R MS Rx connector	-11	dBm
GSM-R MS Blocking criteria	-38	dBm
Margin	-27	dB

Table 5-7: Assessment of blocking of GSM-R MS by LTE BTS

From the calculation, it is found that the GSM-R MS blocking criteria is not fulfilled and the LTE interfering power could exceed the system threshold by 27 dB in both scenarios.

The GSM-R blocking criteria is defined in relation to the GSM-R reference sensitivities, these needs to be maintained in presence of blocking levels up to the thresholds specified in the system standard. Thus, reception at the MS could be degraded if the wanted signal level is very low and the blocking level exceeds the threshold. This might be the case in the scenario with individual sites where the GSM-R MS could be far away from the serving GSM-R BTS but close to an interfering LTE BTS.

Yet, in the "Same Site" scenario, the GSM-R and LTE signal received by the MS are both in the same range, which means that different conditions as considered by the blocking definition might apply.

**GSM-R Downlink: Summary**

The results of the analysis for a frequency separation of  $\Delta f = 200$  kHz are summarized in the table below. The table gives the margins in relation to acceptable values. Negative values are critical and marked in red:

Scenario	In Band Interference Analysis	Blocking Analysis
Individual Sites	-55 dB	-27 dB
Same Site	38 dB	-27 dB

Table 5-8: Calculation results for GSM-R downlink ( $\Delta f = 200$  kHz)

The summary shows that in the scenario with individual sites additional filtering of out-of-band emissions at the LTE base station by approximately 55 dB would be required to reduce interfering power in the GSM-R receive bandwidth. An increase of the guard band to 600 kHz would reduce this requirement to approximately 47 dB, yet still signal blocking could be expected. We therefore conclude that the scenario using individual sites does not seem feasible.

The "Same Site" scenario shows a margin of +38 dB for the in-band interfering power, thus reception of GSM-R would not be affected while still blocking effects are indicated by the calculations in case of high interfering levels and small wanted signal levels at the GSM-R MS. However, as the "Same Site" scenario is characterized by similar signal levels for wanted and interfering signal, high blocking levels would always correlate with high levels for the wanted signal. As this situation is not directly covered by the standard's blocking specification, measurements during the laboratory tests with high GSM-R serving levels and high LTE blocking levels have been done. The measurements did not show negative blocking effects, we therefore conclude that the "Same Site" scenario with a frequency separation of  $\Delta f = 200$  kHz would be feasible.

### 5.3.3 GSM-R Uplink: GSM-R BTS interfered by LTE UE

#### GSM-R Uplink: Scenario Description

The following picture illustrates the two different cases for interference from LTE UE to a GSM-R BTS in uplink. The left picture shows the case for use of separate BTS for LTE and GSM-R the right picture the use of the same BTS:

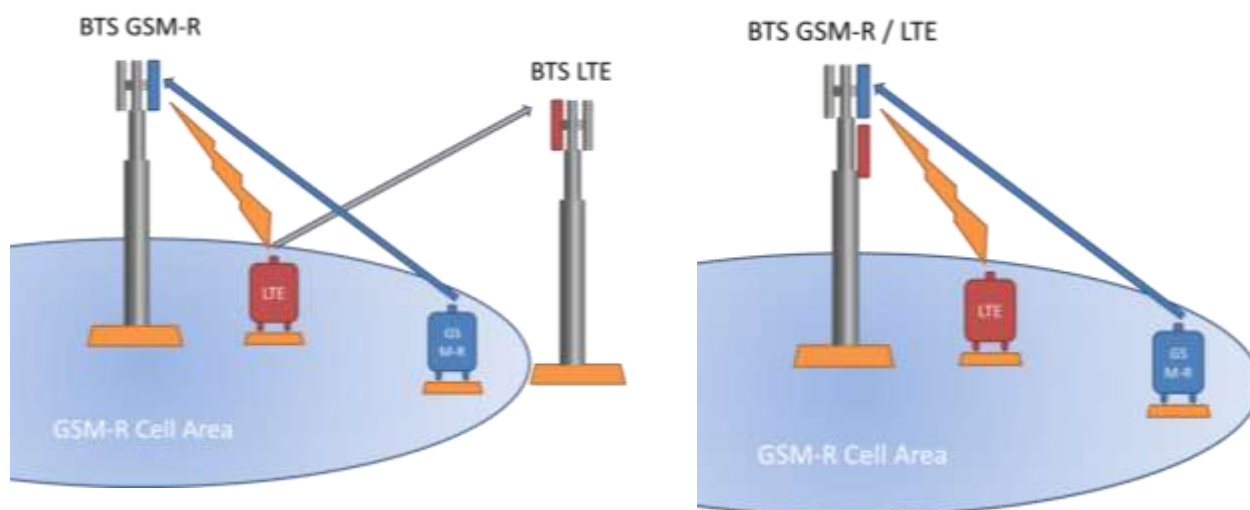

Figure 5-22: Critical scenarios for interference from LTE UE on GSM-R uplink

The worst case for separate BTS is found when the GSM-R BTS is receiving a signal from a GSM-R MS that is located at the cell edge, while the LTE UE is located very close to the GSM-R BTS and is transmitting with high power, either as transmit power control at the LTE UE is not used or as the LTE BTS is located far away.

If both systems use the same site, the worst case is found when the GSM-R MS is located at the cell edge of the GSM-R cell and, thus, received with low signal power and, at the same time, the LTE UE is located very close to the GSM-R BTS and transmitting with high power, either because it is located far away from the serving LTE BTS or because transmit power control at the LTE UE is not used.

The scenario specific parameters for these two cases are given in Table 5-4:

Scenario	Critical Case	Limiting Parameter	Critical Value	Source
Individual Sites	Wanted GSM-R MS is located at cell edge	Effective GSM-R BTS receive sensitivity	-107 dBm	Link budget calculations in Section 9.4.1
		GSM-R in band blocking probability	-26 dBm	3GPP TS 45.005 Section 5.1
	Interfering LTE UE is in close proximity of GSM-R BTS and transmitting with high power	Transmit power LTE UE	23 dBm	3GPP-TS 36.101 Table 6.2.2-1
		LTE UE operating band unwanted emission limits	-8.5 dBm in 30 MHz bandwidth	ETSI EN 301 908-13 Table 4.2.3.1.2-1

		Antenna isolation between LTE UE and GSM-R BTS	45 dB	Section 5.2.2
Same Sites	Wanted GSM-R MS is located at cell edge	Effective GSM-R BTS receive sensitivity	-107 dBm	Link budget calculations in Section 9.4.1
		Interfering LTE UE is in close proximity of GSM-R BTS	Transmit power LTE UE (without TPC)	23 dBm
		Min transmit power LTE UE (with TPC)	-40 dBm	3GPP-TS 36.101 Section 6.3.2.1
		LTE UE operating band unwanted emission limits	Frequency dependant	ETSI EN 301 908-13 Table 4.2.3.1.2-1
		Antenna isolation between LTE UE and GSM-R BTS	45 dB	Section 5.2.2

Table 5-9: Scenario specific parameter for interference from LTE UE to GSM-R BTS

### **GSM-R Uplink: Assessment of in-band interfering Power**

A comparison of the listed parameters shows that without TPC enabled at the LTE UE no difference is found if same or separate sites are used for the BTS. The following table shows the calculation to determine the resulting C/I for these two scenarios:

Parameter	Value			Unit
Guard band	200	400	600	kHz
LTE interfering power in GSM-R channel at LTE UE Tx connector	-0.09	-0.13	-0.13	dBm
Cable losses at LTE UE	3	3	3	dB
Antenna isolation	45	45	45	dB
Max interfering power at connector of GSM-R BTS antenna	-48.09	-48.13	-48.13	dBm
Min required level at GSM-R BTS Rx connector	-107	-107	-107	dBm
Cable and coupling losses at GSM-R BTS	6	6	6	dB
Min wanted power at connector of GSM-R BTS antenna	-101	-101	-101	dBm
Resulting C/I	-52.91	-52.87	-52.87	dB
GSM-R C/I requirement	9.00	9.00	9.00	dB
Margin	-61.91	-61.87	-61.87	dB

Table 5-10: Resulting C/I for interference from LTE UE to GSM-R BTS without TPC at LTE UE

The calculations show that the C/I requirement for the GSM-R uplink cannot be met. To achieve un-interfered operation for the scenario with  $\Delta f = 200$  kHz the out of band emission of the LTE UE would need to be reduced by approximately 62 dB either by ensuring that the distance between LTE UE and GSM-R BTS is large enough or by adding additional filtering at

the LTE UE. Increasing the guard band would not reduce the interfering power (due to the specification of the LTE spectrum emission mask).

Therefore also the case were the LTE UE employs transmit power control TPC and reduces the transmit power in close proximity to the base station has been analysed. Yet, the standard documents 3GPP-TS 36.101 and ETSI EN 301 908-13 define only maximum allowed out of band emissions for UE that operate with the maximum allowed transmit power but do not contain the definition of a spectrum mask that defines relative attenuations of out-of-band in relation to the in-band power. For the calculation of interfering power falling into the GSM-R bandwidth, it has therefore been assumed that the out-of-band emissions are reduced by the same amount as the in-band power. The reduction of the LTE UE's transmit power from 23 dBm to -40 dBm corresponds to a reduction of 63 dB. Table 5-11 shows the analysis results for the scenario where the LTE UE employs transmit power control:

Parameter	Value			Unit
Guard band	200	400	600	kHz
Max interfering power at connector of GSM-R BTS antenna (without TPC)	-0.09	-0.13	-0.13	dBm
Reduction by TPC	63	63	63	dB
Cable losses at LTE UE	3	3	3	dB
Antenna isolation	45	45	45	dB
Max interfering power at connector of GSM-R BTS antenna	-111.09	-111.13	-111.13	dBm
Min required level at GSM-R BTS Rx connector	-107	-107	-107	dBm
Cable and coupling losses at GSM-R BTS	6	6	6	dB
Min wanted power at connector of GSM-R BTS antenna	-101	-101	-101	dBm
Resulting C/I	10.09	10.13	10.13	dB
GSM-R C/I requirement	9.00	9.00	9.00	dB
Margin	1.09	1.13	1.13	dB

Table 5-11: Resulting C/I for interference from LTE UE on GSM-R BTS using same sites with TPC at LTE UE used

The calculation shows, that with use of TPC at the LTE UE the GSM-R C/I requirement of 9 dB could be met, if the taken assumption that the out-of-band emissions of the UE are reduced by the same factor as the in-band-power is justified.

Figure 5-23 shows a spectrum scan with UE in-band power of approximately -41.5 dBm at the input of the spectrum analyser (aggregated over the carrier bandwidth):

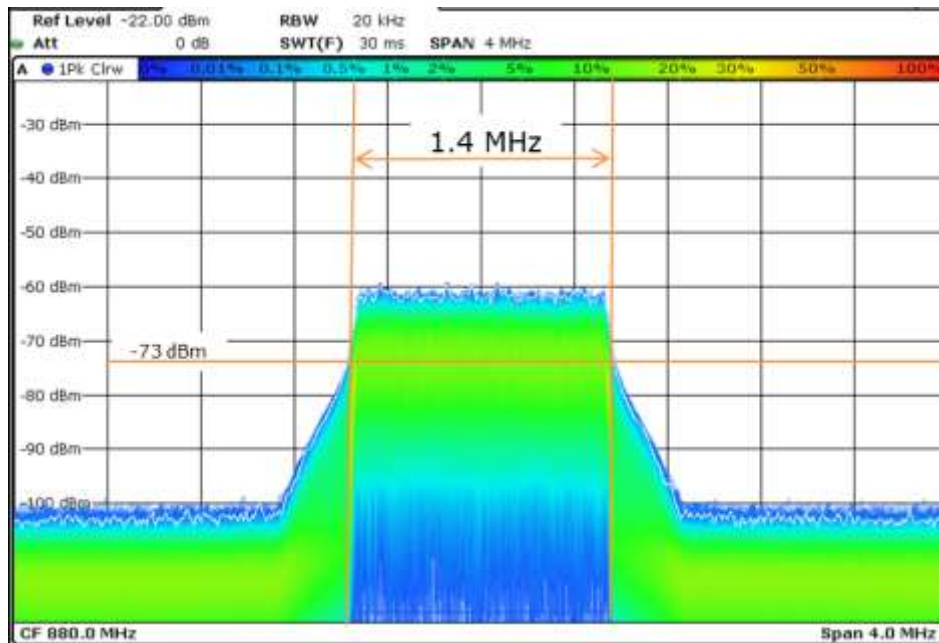

Figure 5-23: Measured spectrum for LTE – UE emissions using 1.4 MHz carrier

According to ETSI EN 301 908-13 the UE would be allowed out-of-band emissions of up to -8.5 dBm (in a 30 kHz measurement bandwidth) for a frequency range up to +/- 2 MHz from the carrier's band edge. This corresponds to approximately -10 dBm in a 20 kHz bandwidth as used in the spectrum scan. With an attenuation of -63 dB as used in the calculation, an allowed out-of-band emission of -73 dBm is found. This requirement is quite well met by the measured spectrum mask shown in Figure 5-23. The figure also shows that the measured out-of-band emissions further decrease with increasing frequency separation from the carrier's band edge. The calculations in Table 5-11 can therefore be considered as conservative, as a constant out-of-band power of -73 dBm has been considered.

### **GSM-R Uplink: Assessment of Blocking Effects**

If the transmitting LTE UE is working close to the interfered GSM-R BTS, blocking of the GSM-R BTS could occur.

Table 5-12 shows the calculation for the worst case where the LTE-UE does not use transmit power control and thus operates with full power very close to the GSM-R BTS:

Parameter	Value	Unit
LTE UE Tx power at LTE UE Tx connector	23	dBm
Cable and coupling losses at LTE BTS	3	dB
LTE UE power at antenna connector of LTE UE antenna	20	dBm
Antenna isolation	45	dBm
LTE blocking power at connector of GSM-R BTS antenna	-25	dBm
Cable and coupling losses at GSM-R BTS	3	dB
Blocking power at GSM-R BTS Rx connector	-28	dBm
GSM-R BTS blocking criteria	-26	dBm
Margin	2	dB

Table 5-12: Assessment of blocking of GSM-R BTS by LTE UE

It is found that the BTS blocking threshold is not exceeded and, thus, negative blocking effects at the BTS do not need to be expected even if no TPC is used at the LTE UE. The use of TPC would reduce the LTE UE Tx power by 63 dB and thus increase the calculated margin by the same amount to 67 dB in the scenario where the same site is shared by GSM-R and LTE.

### **GSM-R Uplink: Summary**

The results of the analysis for the GSM-R uplink with a frequency separation of  $\Delta f = 200$  kHz are summarized in the table below. The table gives the margins in relation to acceptable values. Negative values are critical and marked in red:

Scenario	In Band Interference Analysis		Blocking Analysis	
	Without TPC	With TPC	Without TPC	With TPC
Individual Sites	-62 dB	-62 dB	2 dB	2 dB
Same Site	-62 dB	1.09 dB	2 dB	65 dB

Table 5-13: Calculation results for GSM-R uplink ( $\Delta f = 200$  kHz)

The summary shows that in the scenario with individual sites additional filtering of out-of-band emissions at the LTE UE by approximately 62 dB would be required to reduce interfering power in the GSM-R carrier's receive bandwidth. An increase of the guard band would not reduce this requirement due to the way how the spectrum emission mask for the UE is defined. Blocking effects, however, would not be expected.



Additional filtering of LTE out-of-band emissions would be required in the "Same Site" scenario, if the LTE UE is not using transmit power control. However, in-band interference would remain in the required limits if TPC was used and the LTE's out-of-band emissions were reduced by the same amount as the in-band power. This assumption has been verified during the laboratory tests. As furthermore for the "Individual Site" scenario no blocking effects have been indicated, we therefore conclude that the "Same Site" scenario with a frequency separation of  $\Delta f = 200$  kHz would be feasible.

### 5.3.4 BTS to BTS: GSM-R BTS interfered by LTE BTS

#### GSM-R BTS interfered by LTE BTS: Scenario Description

The following picture illustrates the two different scenarios, where reception at a GSM-R BTS could be interfered by transmission of a LTE BTS. The left picture shows the case for use of different sites for GSM-R and LTE the right picture the use of the same site:



Figure 5-24: Critical scenarios for interference from GSM-R BTS on LTE BTS

Interference in these scenarios might occur if reception of a wanted uplink signal at the GSM-R base station is affected by signals from the LTE BTS transmitting in the downlink band. Thus, the wanted and interfering signals are separated by approximately 45 MHz -  $\Delta f$  as both systems use Frequency Division Duplex (FDD) with a duplex separation of 45 MHz. As for the purpose of the done analyses the frequency separation  $\Delta f$  can be considered small in comparison to the duplex separation, the analysis has been done for a separation of 45 MHz.

With this frequency separation the desensitization of the GSM-R BTS due to spurious emissions of the LTE BTS and due to out-of-band blocking effects need to be considered.

The worst case for both scenarios is found when the GSM-R BTS is receiving a signal from a MS that is located at the cell edge and thus received with levels close to the GSM-R BTS receive sensitivity, while the interfering LTE BTS is located very close to the GSM-R BTS and is transmitting with high power. The relevant parameters are the same for scenarios and given in the table below:

Scenario	Critical Case	Limiting Parameter	Critical Value	Source
Individual Sites	Wanted GSM-R MS is located at cell edge and thus received at small signal level	GSM-R BTS out of band blocking level	8 dBm	3GPP TS 45.005 Section 5.1
		GSM-R BTS noise figure	8 dB	Typical Figure, e.g. ECC report 229
	Interfering LTE BTS is in close proximity of GSM-R BTS and transmitting with high power	LTE BTS spurious emissions	-89 dBm	3GPP TS 36.104 Table 6.6.4.4-1
		GSM-R BTS transmit power	44 dBm	Typical Value Link budget in section 9.4.1
		Antenna isolation	45 dB	Section 5.2
Same Site	Same as in scenario with individual sites			

Table 5-14: Scenario specific parameter for interference from LTE BTS to LTE BTS

### **GSM-R BTS interfered by LTE BTS: Assessment of Desensitization**

To assess the desensitization of the GSM-R BTS the increase of the GSM-R BTS noise floor due to LTE spurious emissions has been calculated:

Parameter	Value	Unit
LTE spurious emissions at LTE BTS Tx connector (100 kHz bandwidth)	-98	dBm
LTE spurious emissions at LTE BTS Tx connector (200 kHz bandwidth)	-95	dBm
Cable and coupling losses at LTE BTS	6	dB
LTE spurious emissions at antenna connector of LTE BTS antenna	-101	dBm
Antenna isolation	45	dBm
LTE interfering power at connector of GSM-R BTS antenna	-146	dBm
Cable and coupling losses at GSM-R BTS	6	dB
LTE interfering power at GSM-R BTS Rx connector	-152	dBm
GSM-R BTS noise figure	8	dB
Thermal noise (200 kHz)	-121.00	dBm
GSM-R BTS receiver noise	-113.00	dBm
GSM-R BTS noise + interferer level	-113.00	dBm
Desensitization	0.00	dB
Acceptable desensitization	1	dB
Margin	1	dB

Table 5-15: Desensitization of GSM-R BTS by LTE BTS

The results from Table 5-15 show that only a negligible desensitization is to be expected.

**GSM-R BTS interfered by LTE BTS: Assessment of Blocking Effects**

In Table 5-16, the blocking power at the GSM BTS Rx connector is calculated and compared against the GSM-R BTS blocking criteria. It is found that the calculated blocking power is 22 dB below the blocking criteria and thus no negative impact at the LTE BTS due to blocking is to be expected:

Parameter	Value	Unit
LTE Tx power at LTE BTS Tx connector	43	dBm
Cable and coupling losses at LTE BTS	6	dB
LTE Tx power at antenna connector of LTE BTS antenna	37	dBm
Antenna isolation	45	dBm
LTE blocking power at connector of GSM-R BTS antenna	-8	dBm
Cable and coupling losses at GSM-R BTS	6	dB
Blocking power at GSM-R MS Rx connector	-14	dBm
GSM-R BTS blocking criteria	8	dBm
Margin	22	dB

Table 5-16: Assessment of Blocking of GSM-R BTS by LTE BTS

**GSM-R BTS interfered by LTE BTS: Summary**

The results of the analysis are summarized in the table below. The table gives the determined margins in relation to acceptable values. Negative values are critical and marked in red:

Scenario	Desensitization	Margin from Blocking Analysis
Individual Sites	1 dB	22 dB
Same Site	1 dB	22 dB

Table 5-17: Calculation results for GSM-R BTS

Considering the results from the blocking assessment and the desensitization calculation, we conclude that no considerable interference from the LTE BTS to the GSM-R BTS is to be expected.

### 5.3.5 UE to MS: GSM-R MS interfered by LTE UE

#### GSM-R MS interfered by LTE UE: Scenario Description

The following picture illustrates the two different scenarios, where reception at a GSM-R MS could be interfered by transmission of a LTE UE. The left picture shows the case for use of GSM-R and LTE on the same train, the right picture the use at separate trains:

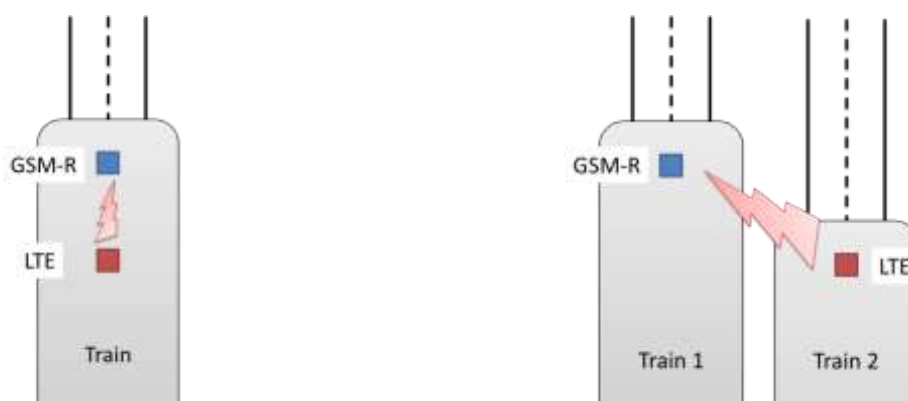

Figure 5-25: Critical scenarios for interference from LTE UE on GSM-R MS

Interference might occur if reception of a wanted downlink signal at the GSM-R MS is affected by signals from the LTE UE transmitting in the uplink band. Thus the wanted and interfering signal are separated by approximately  $45 \text{ MHz} + \Delta f$  as both systems use frequency division duplex FDD with a duplex separation of 45 MHz. As for the purpose of the done analyses the frequency separation  $\Delta f$  can be considered small in comparison to the duplex separation, the analysis has been done for of frequency separation of 45 MHz.

With this frequency separation, the desensitization of the GSM-R MS due to spurious emissions of the LTE UE and out-of-band blocking effects need to be considered.

The worst case for both scenarios is found when both the GSM-R MS and the LTE UE are located at the cell edge. In this case, the GSM-R MS operates close to its receive sensitivity, while the interfering LTE UE transmits with maximum power. The relevant parameters for this scenario are given in the table below:

Scenario	Critical Case	Limiting Parameter	Critical Value	Source
Individual Trains	Both LTE and GSM-UE are located at the cell edge and thus the LTE UE transmits with high transmit power while the GSM-R MS operates at minimum receive level	GSM-R MS blocking level	0 dBm	3GPP TS 45.005 Section 5.1
		GSM-R MS noise figure	8 dB	Typical Figure, e.g. ECC report 229
		LTE UE spurious emissions	-50 dBm	3GPP TS36.101, Table 6.6.3.2-1
		LTE UE transmit power	23 dBm	Link budget in section 9.4.1 System Standard
		Antenna isolation	30 dB	Section 5.2.2

Same Train	Same parameter as in the scenario with individual trains
------------	--

Table 5-18: Scenario specific parameter for interference from LTE UE on GSM-R MS

**GSM-R MS interfered by LTE UE: Assessment of Desensitization**

To assess the desensitization of the GSM-R MS the increase of the GSM-R MS noise floor due to LTE spurious emissions has been calculated:

Parameter	Value	Unit
LTE spurious emissions at LTE UE Tx connector (1 MHz bandwidth)	-50	dBm
LTE spurious emissions at LTE UE Tx connector (200 kHz bandwidth)	-56.9	dBm
Cable and coupling losses at LTE UE	3	dB
LTE spurious emissions at antenna connector of LTE UE antenna	-59.9	dBm
Antenna isolation	30	dB
LTE interfering power at connector of GSM-R MS antenna	-89.9	dBm
Cable and coupling losses at GSM-R MS	3	dB
Interfering Power at GSM-R MS Rx connector	-92.9	dBm
GSM-R MS noise figure	8	dB
Thermal noise (200 kHz)	-121.00	dBm
GSM-R MS receiver noise	-113.00	dBm
GSM-R MS noise + interferer level	-92.95	dBm
Desensitization	20.05	dB
Acceptable desensitization	1	dB
Margin	-19.05	dB

Table 5-19: Desensitization of GSM-R MS by LTE UE

The calculation in Table 5-19 shows that a considerable desensitization due to spurious emissions from the LTE UE could happen under the taken worst case assumptions.

**GSM-R MS interfered by LTE UE: Assessment of Blocking Effects**

In Table 5-20, the blocking power at the GSM-R MS Rx connector is calculated and compared against the GSM-R MS blocking criteria:

Parameter	Value	Unit
LTE UE transmit power at UE Tx connector	23	dBm
Cable and coupling losses at LTE UE	3	dB
LTE UE Tx power at antenna connector of UE antenna	20	dBm
Antenna isolation	30	dB
LTE blocking power at connector of GSM-R MS antenna	-10	dBm
Cable and coupling losses at GSM-R MS	3	dB
Blocking power at GSM-R MS Rx connector	-13	dBm
GSM-R MS blocking criteria	0	dBm
Margin	13	dB

Table 5-20: Assessment of blocking of GSM-R MS by LTE UE

It is found that the calculated blocking power is 13 dB below the blocking criteria and thus no negative impact at the GSM-R MS due to blocking is to be expected.

**GSM-R MS interfered by LTE UE: Summary**

The results of the analysis of LTE UE interference on GSM-R MS are summarized in the table below. The table gives the margins in relation to acceptable values. Negative values are critical and marked in red:

Scenario	Desensitization	Blocking Analysis
Individual trains	-19.05 dB	13 dB
Same train	-19.05 dB	13 dB

Table 5-21: Calculation results for LTE UE

The results show, that no blocking effects would to be expected. However, the calculations also show in worst case a desensitization of approximately 20 dB due to spurious emissions of the LTE UE, which could result in heavy interference of the GSM-R downlink under the taken worst case assumptions.

---

## 5.4 LTE interfered by GSM-R

### 5.4.1 Methodology

Due to the different relevant frequency separations for interference relations between MS-BTS, BTS-BTS and MS-UE different methodologies have been used to assess the interference.

#### **BTS-to-BTS and UE-to-MS Interference**

BTS-to-BTS and UE-to-MS interference are characterized by a frequency separation of approximately 45 MHz between the LTE and the GSM-R signals. Thus, the following effects have been considered:

- Desensitization of the LTE BTS (MS) due to spurious emissions of the GSM-R BTS (MS)
- Out-of-band blocking effects

#### **BTS-to-MS and MS-to-BTS Interference**

These interference relations are characterized by a small frequency separation  $\Delta f$  between the LTE and the GSM-R signals. For the analysis of LTE interference on GSM-R the interference power falling from the interfering LTE carrier into the GSM-R receive band has been calculated.

Using the same approach for the assessment of interference from GSM-R on LTE would require an individual analysis of impact of band specific interference power on the different subcarriers and resource blocks. We therefore used specifications and figures from LTE's adjacent channel selectivity requirements to assess the impact of GSM-R interference on the LTE throughput. The standard defines that the throughput of a reference measurement channel shall be at 95 % of the maximum throughput in the presence of an interfering signal where the power in the adjacent band does not exceed a specific threshold.

In addition to that, we analysed narrow band blocking performance.

### 5.4.2 LTE Downlink: LTE UE interfered by GSM-R BTS

#### **LTE Downlink: Scenario Description**

The following picture illustrates the two different cases for interference from GSM-R BTS to a LTE UE in downlink. The left picture shows the case for use of individual sites for LTE and GSM-R the right picture the use of the same site:

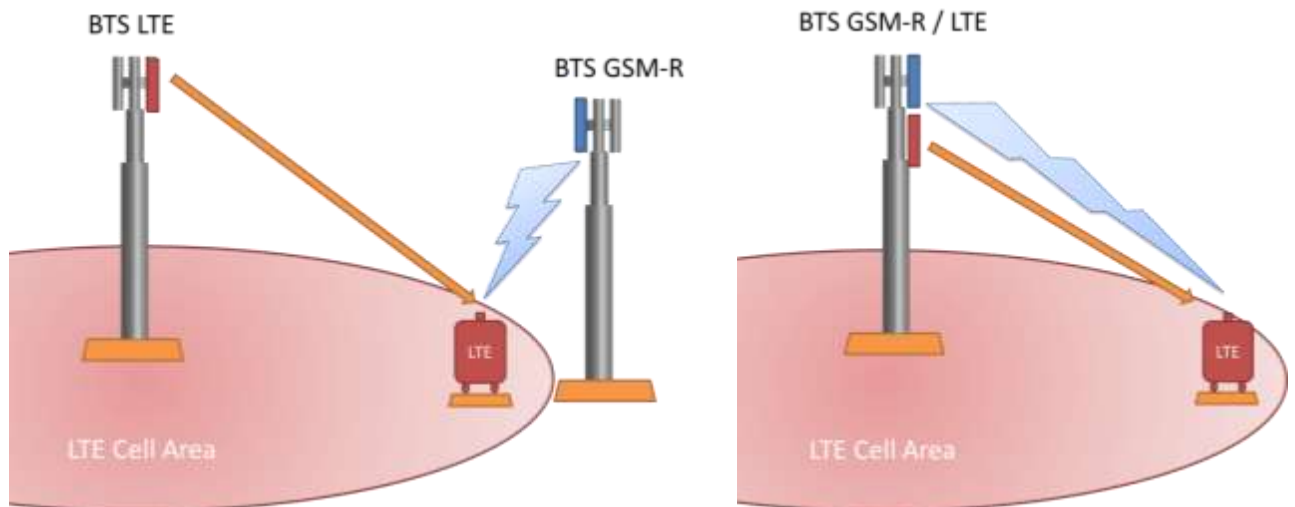

Figure 5-26: Critical scenarios for interference from GSM-R BTS on LTE downlink

The worst case for the scenario with individual BTS is found when the interfered LTE UE is at the cell edge of the LTE cell and, thus, receives the LTE signal at a very low level while, at the same time, it is very close to a GSM-R BTS and, thus, the interfering power is rather high.

In case where both systems use the same site, a comparable path loss for both signals can be assumed if the antennas are at similar height and use similar antenna configurations. This is a reasonable assumption for sites that intend to cover the same track with both systems. Under this assumption the difference in receive level does not change over distance. Therefore, the worst case is also found if the interfered UE is close to the interfering BTS as at this location the interfering level becomes highest.

The scenario specific parameters for these two cases are given in the table below:

Scenario	Critical Case	Limiting Parameter	Critical Value	Source
Individual Sites	Receiving LTE UE is located at cell edge Interfering GSM-R BTS is located in close proximity to receiving LTE UE	LTE UE narrow band blocking criteria at Rx LTE = -80.2 dBm	-55 dBm	3GPP-TS 36.101 Table 7.6.3.1-1
		Permissible UE interfering power in adjacent band		3GPP-TS 36.101
		Rx LTE = -88.2 dBm	-56.7 dBm	Table 7.5.1-2
		Rx LTE = -56.6 dBm	-25 dBm	Table 7.5.1-3
		LTE UE reference sensitivity	-102.2	3GPP-TS 36.101 Table 7.6.3.1-1
		GSM-R BTS transmit power at TX connector	44 dBm	Typical Value Link budget in section 9.4.1
		Isolation between LTE BTS and GSM-R MS	45 dB	Section 5.2.2



Same Site	Receiving LTE is in close proximity to the transmitting site as at this location the interfering level from GSM-R is the highest.	Same as in scenario with individual sites
-----------	---	---

Table 5-22: Scenario specific parameter for interference from GSM-R BTS to LTE UE

### **LTE Downlink: Assessment of adjacent Channel Power**

In the 3GPP standard the permissible interfering power in adjacent band is defined for different levels of the UE receive level. The relevant figures from Table 5-22 are repeated below and the permissible difference between UE receive level and interfering power in the adjacent band is calculated:

UE Receive Level ( $Rx_W$ )	Permissible interfering Power in adjacent Band ( $Rx_I$ )	Permissible Difference $\Delta p = Rx_I - Rx_W$
-88.2 dBm	-56.7 dBm	31.5 dB
-56.6 dBm	-25 dBm	31.6 dB

Table 5-23: Determination of permissible difference between UE receive level and interfering power in adjacent band.

The above table shows that the difference  $\Delta p$  should not exceed a threshold of 31.5 dB, yet the calculations in Table 5-24 reveals that this requirement cannot be met for the "Individual Site" scenario where  $\Delta p$  could reach more than 90 dB:

Parameter	Value	Unit
GSM-R transmit power at GSM-R BTS Tx connector	44	dBm
Cable and coupling losses at GSM-R BTS	6	dB
GSM-R Tx power at antenna connector of GSM-R BTS antenna	38	dBm
Antenna isolation	45	dBm
GSM-R interfering power at connector of LTE UE antenna	-7	dBm
Cable losses at LTE UE	3	dB
Interfering power in adjacent band at LTE UE Rx connector	-10	dBm
LTE UE reference sensitivity	-102.2	dBm
Achieved difference $\Delta p = Rx_I - Rx_W$	92.2	dB
Permissible difference $\Delta p = Rx_I - Rx_W$	31.5	dB
Margin	-60.7	dB

Table 5-24: Assessment of adjacent channel power criteria for GSM-R BTS interfering LTE UE ("Individual Site" scenario)

The calculations for the "Same Site" scenario are found in the following table:

Parameter	Value	Unit
GSM-R BTS Tx power at GSM-R BTS Tx connector	44	dBm
Cable and coupling losses at GSM-R BTS	6	dB
Antenna gain at GSM-R BTS	18	dB
EIRP of transmitted interfering power	56	dBm
LTE BTS Tx power at BTS Tx connector	43	dBm
Cable and coupling losses at GSM-R BTS	6	dB
Antenna gain at LTE BTS	18	dB
EIRP of transmitted interfering power	55	dBm
Achieved difference $\Delta p = Rx_I - Rx_W$	1	dB
Permissible difference $\Delta p = Rx_I - Rx_W$	31.5	dB
Margin	30.5	dB

Table 5-25: Assessment of adjacent channel power criteria for GSM-R BTS interfering LTE UE (“Same Site” scenario)

In contrast to the “Individual Site” scenario, a positive margin of 30.5 dB is found, indicating that for the “Same Site” scenario the permissible adjacent channel interference will not be exceeded and, thus, no interference is to be expected.

### **LTE Downlink: Assessment of Blocking Effects**

The calculations to assess the impact of narrow band blocking are found in the table below:

Parameter	Value	Unit
GSM-R transmit power at GSM-R BTS Tx connector	44	dBm
Cable and coupling losses at GSM-R BTS	6	dB
GSM-R Tx power at antenna connector of GSM-R BTS antenna	38	dBm
Antenna isolation	45	dBm
GSM-R interfering power at connector of LTE UE antenna	-7	dBm
Cable losses at LTE UE	3	dB
Interfering power in adjacent band at LTE UE Rx connector	-10	dBm
LTE UE narrow band blocking criteria	-55	dBm
Margin	-45	dB

Table 5-26: Calculation of blocking power for GSM-R BTS interfering LTE UE

With a maximum possible interfering level of -10 dBm in the adjacent band at the LTE UE Rx connector, the LTE UE narrow band blocking criteria of -55 dBm cannot be met. Considering that the criteria has been defined for a receive level for the wanted signal of -80 dBm, it is obvious that the case would be more severe if the signal from the wanted BTS is even smaller.

This is how it might be in the “*Individual Site*” scenario, when the LTE UE is located at the cell border but close to an interfering GSM-R BTS.

Yet, in the “*Same Site*” scenario, the GSM-R and LTE signal received by the MS are both in the same range, which means that different conditions as considered by the blocking definition might apply. This assumption is supported by the definition of permissible interfering power in adjacent bands, where at a receive level for LTE of -56 dBm interfering levels in the adjacent band of up to -25 dBm are allowed before the throughput is reduced by more than 5 %. It is therefore anticipated that, in the “*Same Site*” scenario for LTE receive levels up to -56 dBm, no serious degradation of the LTE throughput is to be expected.

**LTE Downlink: Summary**

The results of the analysis for the LTE downlink are summarized in the table below. The table gives the margins in relation to acceptable values. Negative values are critical and marked in red:

Scenario	Adjacent Carrier Interfering Analysis	Blocking Analysis
Individual Sites	-60.7 dB	-45 dB
Same Site	30.5 dB	-45 dB

Table 5-27: Calculation results for GSM-R downlink

The summary shows that in the scenario with individual sites additional filtering at the LTE UE to increase adjacent channel suppression by approximately 60 dB would be required to reduce the impact of the GSM-R carrier. As also heavy blocking effects have been indicated, we conclude that the scenario with individual sites is not feasible.

The “*Same Site*” scenario shows a margin of +30.5 dB for the analysis of adjacent carrier power, thus reception of the LTE downlink signal would not be affected by this effect. However, the blocking calculations indicate blocking effects. Yet as the “*Same Site*” scenario is characterized by similar signal levels for wanted and interfering signal, high blocking levels would always correlate with high levels for the wanted signal. As the specification allows at receive levels for LTE of -56 dBm interfering levels interfering power in the adjacent band of up to -25 dBm we anticipate that in the “*Same Site*” scenario for LTE receive levels up to at least -56 dBm no serious degradation of the LTE throughput is to be expected.

### 5.4.3 Uplink: LTE BTS interfered by GSM-R MS

The following picture illustrates the two different cases for interference from GSM-R MS to a LTE BTS in uplink. The left picture shows the case for use of different BTS for LTE and GSM-R the right picture the use of the same BTS.

#### LTE Uplink: Scenario Description

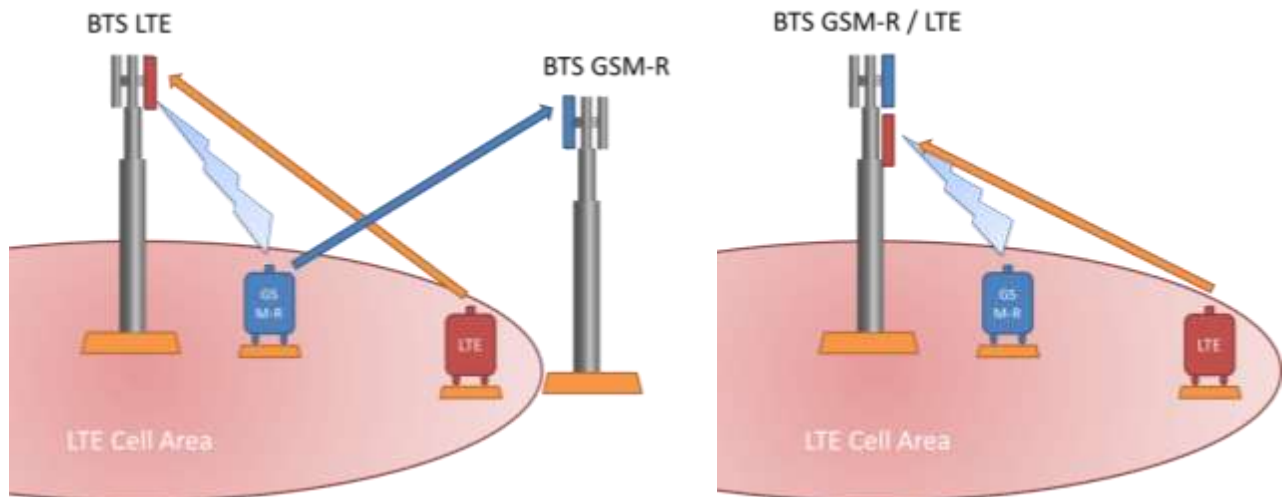

Figure 5-27: Critical scenarios for interference from GSM-R MS on LTE uplink

The worst case for separate BTS is found when the LTE BTS is receiving a signal from a LTE UE that is located at the cell edge, while the interfering GSM-R MS is located very close to the GSM-R BTS and is transmitting with high power, either as transmit power control at the LTE UE is not used or as the LTE BTS is located far away.

In the scenario where both systems use the same site, worst case is found when the LTE UE is located at the cell edge of the LTE cell and, thus, received with low signal power and, at the same time, the GSM-R MS is located very close to the LTE BTS and transmitting with high power (like it could be the case if transmit power control at the GSM-R MS is not used).

The scenario specific parameters for these two cases are given in the table below:

Scenario	Critical Case	Limiting Parameter	Critical Value	Source
Individual Sites	Wanted LTE- UE is located at cell edge  Interfering GSM-UE is in close proximity of LTE BTS and transmitting with high power	LTE BTS narrow band blocking criteria at Rx LTE = -100.8 dBm	-49 dBm	3GPP-TS 36.104 Table 7.5.1-1
		Permissible UE interfering power in adjacent band at Rx LTE = -95.8 dBm	-52 dBm	3GPP-TS 36.104 Table 7.5.1-3
		LTE BTS reference sensitivity	-106.8 dBm	3GPP-TS 36.104 Table 7.5.1-1

		GSM-R MS transmit power at TX connector	39 dBm	3GPP TS 45.005 Section 4.1.1	
		Antenna isolation	45 dB	Section 5.2.2	
Same Sites	Wanted LTE UE is located at cell edge	LTE BTS narrow band blocking criteria at Rx LTE = -100.8 dBm	-49 dB	3GPP-TS 36.104 Table 7.5.1-1	
		Permissible UE interfering power in adjacent band at Rx LTE = -95.8 dBm	-52 dBm	3GPP-TS 36.104 Table 7.5.1-3	
	Interfering GSM-R MS is in close proximity of LTE BTS and transmitting with high power	GSM-R MS transmit power at TX connector			3GPP TS 45.005 Section 4.1.1
		without TPC	39 dBm		
with TPC	5 dBm				
		Antenna isolation	45 dB	Section 5.2.2	

Table 5-28: Scenario specific parameter for interference from GSM-R MS to LTE BTS

### **LTE Uplink: Assessment of Adjacent Carrier Power**

In the 3GPPP standard, an interfering power of -59 dBm in adjacent band is allowed at BTS receive levels of approximately -95 dBm. This results in a maximum permissible  $\Delta p = Rx_I - Rx_W$  of approximately 36 dB. The calculations in Table 5-24 reveals that this requirement cannot be met for the "Individual Site" scenario where  $\Delta p$  could reach more than 80 dB assuming a receive level of approximately -95 dB for the wanted signal in the LTE uplink:

Parameter	Value	Unit
GSM-R transmit power at GSM-R MS Tx connector	39	dBm
Cable losses at GSM-R MS	3	dB
GSM-R Tx power at antenna connector of MS antenna	36	dBm
Antenna isolation	45	dBm
GSM-R interfering power at connector of LTE BTS antenna	-9	dBm
Cable and coupling losses at LTE BTS	6	dB
Interfering power in adjacent band at LTE UE Rx connector	-15	dBm
LTE BTS receive level for definition of permissible adjacent channel power	-95.8	dBm
Achieved difference $\Delta p = Rx_I - Rx_W$	80.8	dB
Permissible difference $\Delta p = Rx_I - Rx_W$	36	dB
Margin	-44.8	dB

Table 5-29: Assessment of adjacent channel power criteria for GSM-R MS interfering LTE BTS ("Individual Site" scenario)

For signals at level in the range of the LTE BTS reference sensitivity (approximately -107 dBm) the situation would even be more severe. Thus, the “*Individual Site*” scenario seems not to be feasible.

The same calculation has been repeated for the scenario with same sites, however in this case also the use of TPC in the uplink has been considered:

Parameter	Value		Unit
	Without TPC	With TPC	
GSM-R transmit power at GSM-R MS Tx connector	39	5	dBm
Cable losses at GSM-R MS	3	3	dB
GSM-R Tx power at antenna connector of MS antenna	36	2	dBm
Antenna isolation	45	45	dBm
GSM-R interfering power at connector of LTE BTS antenna	-9	-43	dBm
Cable and coupling losses at LTE BTS	6	6	dB
Interfering power in adjacent band at LTE UE Rx connector	-15	-49	dBm
LTE BTS receive level for definition of permissible adjacent channel power	-95.8	-95.8	dBm
Achieved difference $\Delta p = Rx_I - Rx_W$	80.8	46.8	dB
Permissible difference $\Delta p = Rx_I - Rx_W$	36	36	dB
Margin	-44.8	-10.8	dB

Table 5-30: Assessment of adjacent channel power criteria for GSM-R MS interfering LTE BTS (“*Same Site*” scenario)

For the case without TPC, the same figure is found as in the “*Individual Site*” scenario, however, a smaller margin of -10.8 dB is found if TPC is used. Assuming that the same permissible difference of  $\Delta p=36$  dB applies as well at the BTS reference sensitivity level additional filter at the BTS to decrease the adjacent channel selectivity by approximately 21 dB would be needed to make the “*Same Site*” scenario feasible.

### LTE Uplink: Assessment of Blocking Effects

The following table shows the calculation of the blocking power at the LTE BTS Rx connector. An evaluation is done in case where the GSM-R MS does not use transmit power control TPC and in case that TPC is used. The case without TPC applies to both the "Individual Site" and the "Same Site" scenario, while the case with TPC applies only to the "Same Site" scenario:

Parameter	Value		Unit
	Without TPC	With TPC	
GSM-R transmit power at GSM-R MS Tx connector	39	5	dBm
Cable losses at GSM-R MS	3	3	dB
GSM-R Tx power at antenna connector of MS antenna	36	2	dBm
Antenna isolation	45	45	dBm
GSM-R interfering power at connector of LTE BTS antenna	-9	-43	dBm
Cable and coupling losses at LTE BTS	6	6	dB
Interfering power in adjacent band at LTE UE Rx connector	-15	-49	dBm
LTE BTS narrow band blocking criteria	-49	-49	dB
Margin	-40	0	dB

Table 5-31: Calculation of blocking power for GSM-R MS interfering LTE BTS

With a maximum possible interfering level of -15 dBm in the adjacent band at the LTE UE Rx connector, the LTE BTS's narrow band blocking criteria is exceeded by 40 dB and, thus, a severe reduction of the uplink throughput might be observed if TPC at the GSM-R MS is not used. In case that TPC is used, the interfering power is reduced to -49 dBm and, thus, the BTS's narrow band blocking criteria would just be met and the reduction in uplink throughput should not exceed 5% for signals received at a signal level of -100.8 dBm.

### LTE Uplink: Summary

The results of the analysis for the LTE uplink are summarized in the table below. The table gives the margins in relation to acceptable values. Negative values are critical and marked in red:

Scenario	Adjacent Carrier Power Analysis		Blocking Analysis	
	Without TPC	With TPC	Without TPC	With TPC
Individual Sites	-44.8 dB	-44.8 dB	-40 dB	-40 dB
Same Site	-44.8 dB	-10.8 dB	-40 dB	0 dB

Table 5-32: Calculation results for LTE uplink

The summary shows that in the scenario with individual sites additional filtering at the LTE BTS to increase adjacent channel suppression by approximately 45 dB would be required to reduce the impact of the GSM-R carrier. As also heavy blocking effects have been indicated, we conclude that the scenario with individual sites is not feasible.

The "same site" scenario shows a margin of -10.8 for the adjacent carrier, which has been determined for a wanted receive level of -95 dBm. Thus additional filtering to suppress signals in the adjacent band by approximately 21 dB would be required to avoid interference for signals received at the reference receive level of -105 dBm. The blocking analysis showed that with TPC enabled at the GSM-R MS the reduction of uplink throughput would remain below 5% for receive levels down to -100 dBm.

#### 5.4.4 BTS to BTS: GSM-R BTS interfered by LTE BTS

##### LTE BTS interfered by GSM-R BTS: Scenario Description

The following picture illustrates the two different scenarios, where reception at an LTE BTS could be interfered by transmission of a GSM-R BTS. The left picture shows the case for use of different sites for LTE and GSM-R the right picture the use of the same site:

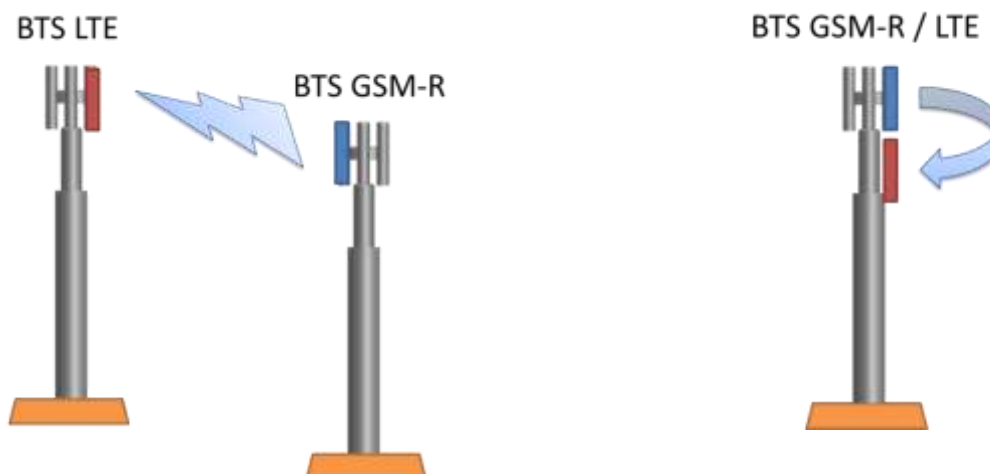

Figure 5-28: Critical scenarios for interference from GSM-R BTS on LTE BTS

Interference might occur if reception of a wanted uplink signal at the LTE base station is affected by signals from the GSM-R BTS transmitting in the downlink band. Thus the wanted and interfering signal are separated by approximately  $45 \text{ MHz} + \Delta f$  as both systems use frequency division duplex FDD with a duplex separation of 45 MHz. As for the purpose of the done analyses the frequency separation  $\Delta f$  can be considered small in comparison to the duplex separation, the analysis has been done for a frequency separation of 45 MHz.

With this frequency separation the desensitization of the LTE BTS due to spurious emissions of the GSM-R BTS and out-of-band blocking effects need to be considered.

The worst case for both scenarios is found when the LTE BTS is receiving a signal from a LTE UE that is located at the cell edge and thus received with levels close to the LTE BTS receive sensitivity, while the interfering GSM-R BTS is located very close to the LTE BTS and is transmitting with high power. The relevant parameters are the same for both scenarios as given in the table below:



Scenario	Critical Case	Limiting Parameter	Critical Value	Source
Individual Sites	Wanted LTE UE is located at cell edge and thus received at small signal level	LTE BTS blocking level for co-located BTS	16 dBm	3GPP TS 36.104 Table 7.6.2.1-1
		LTE BTS noise figure	5 dB	3GPP TR 25.814 Table A.2.1.8-1
	Interfering GSM-R BTS is in close proximity of the LTE BTS and transmitting with high power	GSM- R BTS spurious emissions in BTS receive band	-89 dBm	3GPP TS 45.005 Section 4.2.2.1
		GSM-R BTS transmit power	44 dBm	Typical Value Link budget in section 9.4.1
		Antenna isolation	45 dB	Section 5.2
Same Site	Same as in scenario with individual sites			

Table 5-33: Scenario specific parameter for interference from GSM-R BTS to LTE BTS

#### **LTE BTS interfered by GSM-R BTS: Assessment of Desensitization**

To assess the desensitization of the LTE BTS the increase of the LTE BTS noise floor due to GSM-R spurious emissions has been calculated:

Parameter	Value	Unit
GSM-R spurious emissions at GSM-R BTS Tx connector (100 kHz bandwidth)	-89	dBm
GSM-R spurious emissions at GSM-R BTS Tx connector (1.4 MHz bandwidth)	-77.54	dBm
Cable and coupling losses at GSM-R BTS	6	dB
GSM-R spurious emissions at antenna connector of GSM-R BTS antenna	-83.54	dBm
Antenna isolation	45	dBm
GSM-R interfering power at connector of LTE BTS antenna	-128.54	dBm
Cable and coupling losses at LTE BTS	6	dB
GSM-R interfering power at LTE BTS Rx connector	-134.54	dBm
LTE BTS noise figure	5	dB
Thermal Noise (1.4 MHz)	-112.50	dBm
LTE BTS Receiver Noise	-107.50	dBm
LTE BTS Noise + Interferer level	-107.49	dBm
Desensitization	0.01	dB
Acceptable desensitization	1	dB
Margin	0.99	dB

Table 5-34: Desensitization of LTE BTS by GSM-R BTS

The results from Table 5-34 show that only a negligible desensitization of approximately 0.01 dB is to be expected.

**LTE BTS interfered by GSM-R BTS: Assessment of Blocking Effects**

In Table 5-35, the blocking power at the LTE BTS Rx connector is calculated and compared against the LTE BTS blocking criteria:

Parameter	Value	Unit
GSM-R Tx power at GSM-R BTS Tx connector	44	dBm
Cable and coupling losses at GSM-R BTS	6	dB
GSM-R Tx power at antenna connector of GSM-R BTS antenna	38	dBm
Antenna isolation	45	dB
GSM-R blocking power at connector of LTE BTS antenna	-7	dBm
Cable and coupling losses at LTE BTS	6	dB
Blocking power at LTE BTS Rx connector	-13	dBm
LTE BTS blocking criteria	16	dBm
Margin	29	dB

Table 5-35: Assessment of Blocking of LTE BTS by GSM-R BTS

It is found that the calculated blocking power is 29 dB below the blocking criteria and thus no negative impact at the LTE BTS due to blocking is to be expected.

**LTE BTS interfered by GSM-R BTS: Summary**

The results of the analysis are summarized in the table below. The table gives the margins in relation to acceptable values. Negative values are critical and marked in red:

Scenario	Desensitization	Blocking Analysis
Individual Sites	0.99 dB	29 dB
Same Site	0.99 dB	29 dB

Table 5-36: Calculation results for LTE BTS

Considering the results from the blocking assessment and the desensitization calculation, we conclude that no considerable interference from the GSM-R BTS to the LTE BTS is to be expected.

## 5.4.5 MS to UE: LTE UE interfered by GSM-R MS

### LTE UE interfered by GSM-R MS: Scenario Description

The following picture illustrates the two different scenarios, where reception at a LTE UE could be interfered by transmission of a GSM-R MS. The left picture shows the case for use of GSM-R and LTE on the same train, the right picture the use at individual trains:



Figure 5-29: Critical scenarios for interference from GSM-R MS to LTE UE

Interference might occur if reception of a wanted downlink signal at the LTE UE is affected by signals from the GSM-R MS transmitting in uplink band. Thus the wanted and interfering signal are separated by approximately 45 MHz -  $\Delta f$  as both systems use frequency division duplex FDD with a duplex separation of 45 MHz. As for the purpose of the done analyses the frequency separation  $\Delta f$  can be considered small in comparison to the duplex separation, the analysis has been done for of frequency separation of 45 MHz.

With this frequency separation, the desensitization of the LTE UE due to spurious emissions of the GSM-R MS and out-of-band blocking effects need to be considered.

The worst case for both scenarios is found when both the GSM-R MS and the LTE UE are located at the cell edge. In this case, the LTE UE operates close to its receive sensitivity, while the interfering GSM-R MS transmits with maximum power. The relevant parameters for this scenario are given in the table below:

Scenario	Critical Case	Limiting Parameter	Critical Value	Source
Individual Trains	Both LTE and GSM-UE are located are at the cell edge and thus GSM-R MS transmits with high transmit power while the LTE UE operates at minimum receive level	LTE UE blocking level	-44 dBm	3GPP TS36.101 Table 7.6.2.1-2
		LTE UE noise figure	9 dB	3GPP TR 25.814 Table A.2.1.6-1
		GSM-R MS spurious emissions	-36 dBm	3GPP TS45.005 Section 5.1
		GSM-R MS transmit power	39 dBm	3GPP TS 45.005 Section 4.1.1
		Antenna isolation	30 dB	Section 5.2.2

Scenario	Critical Case	Limiting Parameter	Critical Value	Source
Same Train	Same parameter as in the scenario with individual trains			

Table 5-37: Scenario specific parameter for interference from GSM-R MS to LTE UE

**LTE UE interfered by GSM-R MS: Assessment of desensitization**

To assess the desensitization of the LTE UE the increase of the LTE UE noise floor due to GSM-R spurious emissions has been calculated:

Parameter	Value	Unit
GSM-R spurious emissions at GSM-R MS Tx connector (100 kHz)	-36	dBm
GSM-R spurious emissions at GSM-R MS Tx connector (1.4 MHz)	-24.54	dBm
Cable and coupling losses at GSM-R MS	3	dB
GSM-R spurious emissions at antenna connector of GSM-R MS antenna	-27.54	dBm
Antenna isolation	30	dB
GSM-R interfering power at connector of LTE UE antenna	-57.54	dBm
Cable and coupling losses at LTE UE	3	dB
Interfering power at LTE UE Rx connector	-60.54	dBm
LTE UE noise figure	9	dB
Thermal noise (1.4 MHz)	-112.50	dBm
LTE UE receiver noise	-103.50	dBm
LTE UE noise + interferer level	-60.54	dBm
Desensitization	42.96	dB
Acceptable desensitization	1	dB
Margin	-41.96	dB

Table 5-38: Desensitization of LTE UE by GSM-R MS

The calculation in the table above shows that a considerable desensitization due to spurious emissions from the GSM-R might happen under the taken worst case assumptions.

### **LTE UE interfered by GSM-R MS: Assessment of blocking Effects**

In Table 5-20, the blocking power at the LTE UE Rx connector is calculated and compared against the LTE UE blocking criteria:

Parameter	Value	Unit
GSM-R MS transmit power at UE Tx connector	39	dBm
Cable and coupling losses at GSM-R MS	3	dB
GSM-R MS Tx power at antenna connector of UE antenna	36	dBm
Antenna isolation	30	dB
GSM-R blocking power at connector of LTE UE antenna	6	dBm
Cable and coupling losses at LTE UE	3	dB
Blocking power at LTE UE Rx connector	3	dBm
LTE UE blocking criteria	-44	dBm
Margin	-47	dB

Table 5-39: Assessment of blocking of LTE UE by GSM-R MS

It is found that the calculated blocking power is 47 dB above the blocking criteria and, thus, blocking effects are to be expected.

### **LTE UE interfered by GSM-R UE: Summary**

The results of the analysis of LTE UE interference on GSM-R ME are summarized in the table below. The table gives the margins in relation to acceptable values. Negative values are critical and marked in red:

Scenario	Desensitization	Blocking Analysis
Individual trains	-41.96 dB	-47 dB
Same train	-41.96 dB	-47 dB

Table 5-40: Calculation results for LTE UE

The results show, that both blocking effects as well as considerable desensitization of approximately 43 dB due to spurious emissions of the GSM-R UE might happen, which could result in heavy interference of the LTE downlink.

## 5.5 Summary on Sharing Calculations

Individual sharing calculations have been done for eight different interference relations considering GSM-R BTS and MS as well as LTE BTS and UE both as interferers and as victims. The analysis has been done for two different network implementation scenarios, the one assuming individual sites for GSM-R and LTE, the other assuming that both networks use the same sites.

To assess the impact of band sharing, the scenarios have been evaluated in regard to relevant interference effects like system desensitization or degradation due to in-band and adjacent band interfering power and in regard to blocking effects.

For each relevant interference effect a margin has been derived, that gives the difference between relevant performance criteria from the 3GPP system standards (e.g. acceptable blocking level) and the value resulting from the analysis (e.g. achieved blocking level). Positive margins indicate that the relevant criteria can be met and thus it is theoretically feasible to share the band between the two technologies. Negative margins indicate cases where the necessary criteria for interoperation cannot be met and thus some form of mitigation may be necessary.

Where appropriate, calculations have been done for guard bands  $\Delta f$  in a range of 200 kHz to 600 kHz between the band edges of the GSM-R carrier and the LTE carrier. For calculations in uplink both scenarios with and without use of transmit power control at the MS / UE have been analysed.

For uplink calculation scenarios with and without use of transmit power control (TPC) at the MS / UE has been considered.

The following tables give a summary on the margins that resulted from the different analyses. Several interference effects have been analysed (e.g. blocking and desensitization) for each interference relation. The tables give therefore the smallest margin found from any of the analyses as these indicate the most critical cases.

Table 5-41 gives the results for the "Individual Site" scenario assuming a guard band  $\Delta f$  of 200 kHz. The same margins have been found, regardless whether TPC in uplink was considered or not. Negative margins indicate critical cases and are marked red:

Interferer		Victim			
		GSM-R		LTE	
		BTS	MS	BTS	UE
GSM-R	BTS	-	-	1 dB	-61 dB
	MS	-	-	-45 dB	-47 dB
LTE	BTS	1 dB	-62 dB	-	-
	UE	-55 dB	-19 dB	-	-

Table 5-41: Minimum margins found for "Individual Site" scenario

The most critical interference situation for the "Individual Site" scenario has been found, where a mobile station (e.g. a GSM-R MS) is located at the cell edge of its serving cell and is at the same site very close to a LTE BTS. In consequence the GSM-R is operating with very receive

levels while suffering at the same under high interference levels from the LTE BTS. As the GSM-R MS uses at the same time high transmit powers to reach the distant GSM-R BTS, also high interference levels are found at the nearby LTE BTS. This is reflected by the very low margins for the LTE BTS – to GSM-R MS interference of -45 dB and LTE UE to GSM-R BTS interference of -62 dBm. Using TPC at the GSM-R MS in uplink would not improve the situation, as even with TPC enabled the GSM-R MS would use its full transmit power at the cell edge. The same scenario can be sketched for MS UE interfered by GSM-R BTS, resulting in comparable low margins for the specific cases.

The described scenario where a MS/UE is far from its serving cell and at the same time in close vicinity of an interfering cell can be avoided by coordinated planning of site locations. An extreme of this approach is found when the same site for both systems is used.

Results for this “Same Site” scenario with a guard band of 200 kHz are given in the table below. It has been found that the use of TPC is improving the situation in uplink; therefore, figures for both cases are given:

Interferer		Victim			
		GSM-R		LTE	
		BTS	MS	BTS	UE
GSM-R	BTS	-	-	1 dB	-45 dB
	MS	-	-	without TPC: -45dB with TPC:-10.8 dB	-47 dB
LTE	BTS	2 dB	-27 dB	-	-
	UE	without TPC: -62 dB with TPC: 1 dB	-19 dB	-	-

Table 5-42: Minimum margins found for “Same Site” scenario

A comparison of the two scenarios shows that the “Same Site” scenario is less critical than the scenario assuming individual sites when TPC is used as this feature reduces the interfere in uplink considerable.

Nevertheless, also in the “Same Site” scenario critical interference figures are found.

The following critical cases for the GSM-R system are found at the GSM-R MS:

- The blocking calculations for the GSM-R MS results in a margin of -27 dB indicating possible signal degradation in case that high interfering levels and small wanted signal levels are found at the GSM-R MS. However, this result is considered conservative, as the definitions of the acceptable blocking level in the 3GPP specification assume, that the wanted signal is received at levels in the range of the MS receive sensitivity while the “Same Site” scenario is characterized by similar signal levels for wanted and interfering signal. Thus, high blocking levels would always correlate with high levels for the wanted signal and thus the impact of the blocking is likely smaller than indicated by the calculation. The analysis based on in-band interfering power further resulted in a margin of +38 dB indicating that no problems due to out-of-band emissions from the LTE BTS are to be expected.
- The analysis of MS – UE interference indicates a margin of -19 dB resulting from desensitization due to spurious emissions of the LTE UE. The result is based on the permissible spurious emissions for the LTE UE. Considering that the relevant receive bandwidth of GSM-R is separated by 45 MHz from the UE transmit frequency these emission could be likely suppressed by additional filtering at the LTE UE if necessary.

---

Critical cases for the LTE system are found both at the LTE BTS and at the LTE UE:

- The uplink calculation shows a margin of -10.8 dB resulting from the assessment of adjacent channel power. This figure has been achieved assuming the use of TPC at the GSM-R mobile station. Thus, additional measures at the LTE BTS, like additional filtering to improve the adjacent channel selectivity by approximately 11 dB would be required to mitigate this effect. At the same time blocking calculations have been performed. With a margin of 0 dB, no blocking effects are to be expected.
- The blocking calculations for the LTE UE results in a margin of -45 dB, which indicates problems due to blocking. This assessment is based on a maximum possible interfering level of -10 dBm in the adjacent band at the LTE UE Rx connector and a LTE UE narrow band blocking criteria of -55 dBm. This criteria is defined for a receive level of -80 dBm for the wanted signal. Yet, in the "Same Site" scenario, the GSM-R and LTE signal received by the MS are both in the same range, which means that different conditions as considered by the blocking definition might apply. This assumption is supported by the definition of permissible interfering power in adjacent bands, where at a receive level for LTE of -56 dBm interfering levels in the adjacent band of up to -25 dBm are allowed before the throughput is reduced by more than 5 %. It is therefore anticipated that, in the "Same Site" scenarios for LTE, for receive levels up to -56 dBm no serious degradation of the LTE throughput is to be expected.
- The analysis of interference from the GSM-R MS to LTE UE results in a margin of -47 dB originating from the blocking analysis. A comparably high figure of -42 dB is found from the analysis of desensitization. However, when assessing these figures it needs to be considered that the separation between GSM-R transmit frequency and the LTE UE receive frequency is approximately 45 MHz. Thus possible blocking effects could be suppressed by adding additional filtering at the LTE UE. Effects due to GSM-R spurious emissions however cannot be suppressed by filtering at the LTE UE as the interfering power falls directly into the LTE receive bandwidth. The margin has been calculated based on worst case assumptions, assuming permissible out-of-band emissions at the GSM-R MS of -36 dBm in a 100 kHz bandwidth, resulting in -25 dBm interfering power in a 1.4 MHz bandwidth. This assumption is likely conservative as, in a realistic case, the spurious emissions are likely to be concentrated in narrower bandwidth and, thus, would affect only a part of the LTE subcarriers.



## 6 Intermodulation Analysis

### 6.1 General

Intermodulation (IM) occurs when two or more frequencies create new and usually unwanted frequencies (intermodulation products). Intermodulation products can cause interference if the newly created frequencies fall in the receiver bandwidth of a communication system. The general equation describing intermodulation frequencies is

$$IM = n_1F_1 + n_2F_2 + n_3F_3 + \dots$$

where  $IM$  are the newly created intermodulation frequencies,  $n_{1,2,3,\dots}$  are integer coefficients (+ or -) and  $F_{1,2,3,\dots}$  are the existing frequencies.

The intermodulation order is the sum of the absolute values of all the integer coefficients, a combination of  $2 \times F_1 - 1 \times F_2$  will thus result in an intermodulation product of third order (IM3).

Intermodulation products are typically generated at non-linear system components. In radio systems, three types of intermodulation need to be considered:

- Receiver produced intermodulation when two or more transmitter signals are mixed at non-linear components in the receiver chain
- Transmitter produced intermodulation when one or more transmitted signals are mixed in a nonlinear component in the transmitter chain
- Passive intermodulation generated at imperfect passive system components like cables, splitters and antennas

Transmitter produced intermodulation results in out-of-band emissions. Requirements on these are specified in the corresponding system standards. Passive intermodulation is typically a problem at base stations and in distributed antenna systems (e.g. used for indoor coverage), where high RF-powers are used. Passive intermodulation is addressed in the planning process by selecting appropriate frequencies and components to avoid inter- and intra-system interference due to intermodulation products.

GSM-R MS are very sensitive to intermodulation interference, as they need to be capable of operating in frequency bands dedicated for railway use as well as in frequency bands used by public mobile networks. In consequence, interference due to receiver intermodulation has been observed in existing GSM-R networks for example between public mobile networks and GSM-R. Different studies like report FM(13)134 [5] and ECC Report 229 [6] describe intermodulation interference in GSM-R downlink due to LTE. Measurements done in UK showed problems in GSM-R downlink due to intermodulation with UMTS ([7], [8])

Thus, interference due to intermodulation might also be found in the analysed sharing scenarios, where a LTE carrier is operated within the band dedicated for GSM-R. The LTE carrier will pass the input filter of the GSM-R MS and could cause interference. A similar situation is found at the LTE UE where the GSM-R signals will pass the LTE UE's input filter if it is assumed that the requirement to operate in railway bands and public bands is also imposed on the LTE UE.

Two parameters are of main interest when analysing intermodulation products:

- The frequency of the intermodulation products, as intermodulation would only cause interference if the intermodulation products fell in the receive bandwidth of a wanted signal.

- The power of the intermodulation products. The power of the intermodulation product depends on the power of the signals mixing at the receiver, the characteristics of the receiver and the order of the intermodulation products.

Interference due to intermodulation is found if intermodulation products within the wanted receive bandwidth exists and the power of the products is high enough to cause interference. As the power of intermodulation products decreases with increasing order of the intermodulation, typically IM3 products are considered in the first instance.

For the theoretical analysis, a 1.4 MHz carrier located at the upper edge of the R-GSM band and one and two GSM-R carriers at different frequency separations has been considered. As LTE uses S-OFDMA for the downlink (and SC-FDMA for the uplink), a set of subcarriers separated by 15 kHz has been modelled for the LTE carrier. It has been assumed that all subcarriers have been active to consider the worst case.

The analysis has focused on the evaluation of number of IM products falling in relevant receive bands. The determination of powers of intermodulation products would require detailed knowledge of the receiver structure, and calculation of bandwidth of the intermodulation products, and has therefore not been done.

In the ongoing sections, the following scenarios are analysed:

- One LTE 1.4 MHz carrier without any further GSM-R carriers active.
- One LTE 1.4 MHz carrier and one active GSM-R carrier operated with guard bands  $\Delta f$  in a range from 0 - 600 kHz
- One LTE 1.4 MHz carrier and 2 active GSM-R carriers with guard bands  $\Delta f$  in a range from 0 - 600 kHz between LTE and the first adjacent GSM-R carrier. A spacing of 400 kHz between the two GSM-R carriers has been considered.
- One LTE 1.4 MHz carrier and all remaining carriers of the R-GSM band active at the same time. This is obviously a hypothetical scenario that allows assessing all possible carrier combinations in a worst case scenario, as the number of IM products of different carrier combinations sums up and thus are included in the calculation result.

The results of the analysis are found in the ongoing sections.

## 6.2 Intermodulation Products falling on GSM-R Carriers

In the first analysis, one active GSM-R carrier and all subcarriers of a 1.4 MHz LTE carrier have been used to determine the number of IM3 products falling into the 2.6 MHz remaining for the R-GSM spectrum if the LTE carrier is located at the upper band edge.

The analysis considered different guard bands  $\Delta f$  as multiples of GSM-R carriers (0 - 600 kHz) between the LTE carrier and the remaining GSM-R carriers. To visualize the results a chart is used that gives for each GSM-R carrier the number of IM products falling into the bandwidth of this carrier.

Figure 6-1 shows the result over the entire relevant range of the R-GSM-R band. GSM-R13 is the carrier directly adjacent to the LTE carrier ( $\Delta f = 0$ ), the carriers GSM-R14 to GSM-R20 are occupied by the LTE carrier and thus not included to the chart. Results for different guard bands  $\Delta f$  between the active GSM-R carrier and the LTE carrier are represented by bars in different colours.

Figure 6-2 shows a detailed view for carriers GSM-R12 and GSM-R13 that allows identifying minor differences between the bars. As it is also of interest where the products origin from, an additional bar "Only LTE carrier active" has been added, that shows the possible IM products

that originate from a scenario where only the LTE subcarriers and no further GSM-R carriers are active and thus are resulting from combinations of LTE subcarriers with themselves:

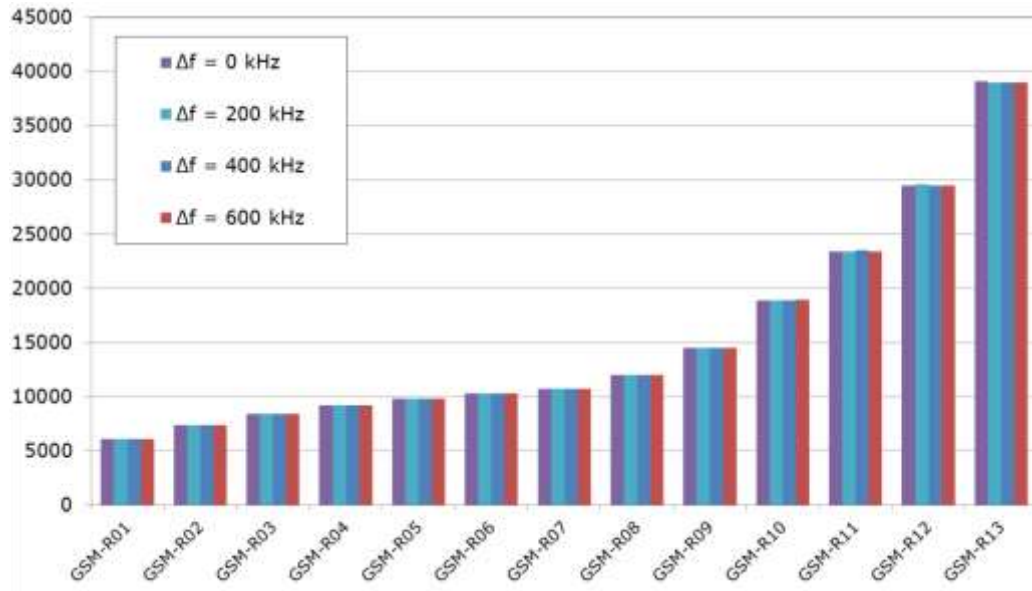

Figure 6-1: Possible IM3 products falling into the R-GSM-band when one active GSM-R carrier is operated with guard band  $\Delta f$

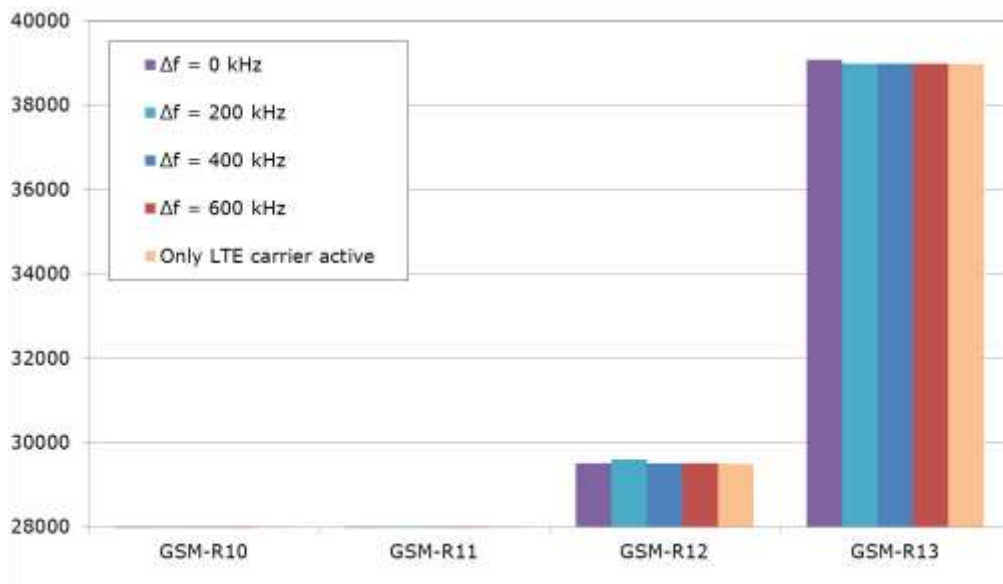

Figure 6-2: Possible IM3 products falling into the R-GSM-band when one active GSM-R carrier is operated with guard band  $\Delta f$  (detailed view)

The following tendencies can be seen from the charts:

- The number of intermodulation products falling into a specific GSM-R carrier decreases, the farther apart the considered carrier is from the LTE carrier.
- The number of intermodulation products changes only slightly with the guard band  $\Delta f$  between the LTE carrier and the GSM-R carrier active in the calculation.
- The highest number of intermodulation products falling in the receive band for a specific GSM-R carrier is found, if the carrier itself has been active in the calculation.

In a second step, the calculations have been repeated with two GSM-R carriers active. The separation between the GSM-R carriers has been 400 kHz and different guard bands have been considered. Figure 6-3 below shows the resulting total number of IM3 products generated by the LTE subcarriers and two GSM-R carriers:

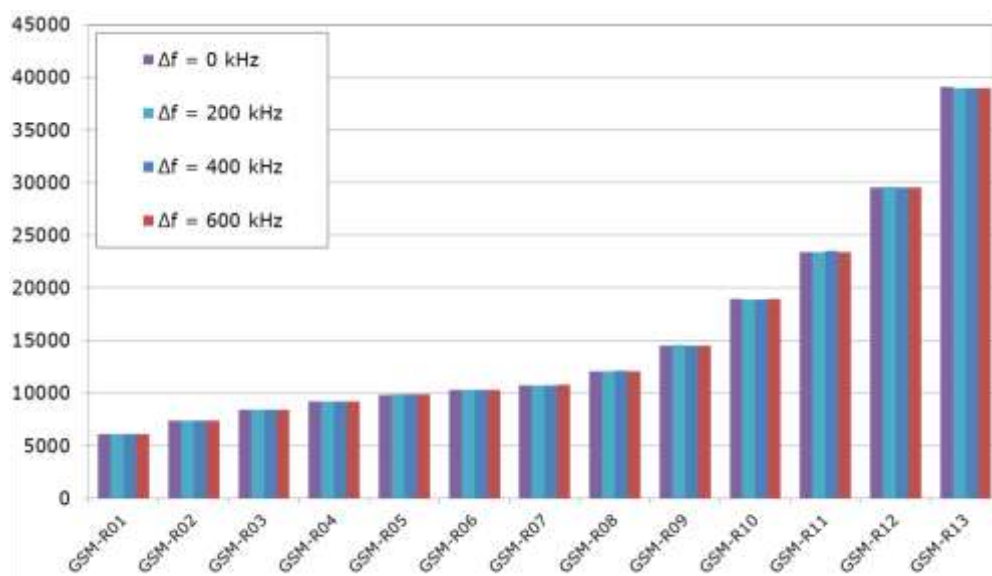

Figure 6-3: Possible IM3 products falling into the R-GSM-band when two GSM-R carriers are active

The results for this scenario with two active GSM-R carriers shows the same tendencies as found from the analysis with one GSM-R carrier. Comparing the results for the two calculations reveals that there is only a slight increase in resulting intermodulation products if the additional GSM-R carrier is added.

In a third step all 12 GSM-R carriers and all LTE subcarriers have assumed active at the same time and the number of IM3 products falling into the GSM-R spectrum have been determined. Figure 6-4 below shows the resulting total number of IM3 products falling into a specific GSM-R carrier. This time also GSM-R carriers GSM-R14 to GSM-R20 have been included to analyse if products are also falling into the bandwidth occupied by the LTE subcarriers. Figure 6-4 compares the results of the calculation with two active GSM-R carriers with the analysis done for all GSM-R carriers active:

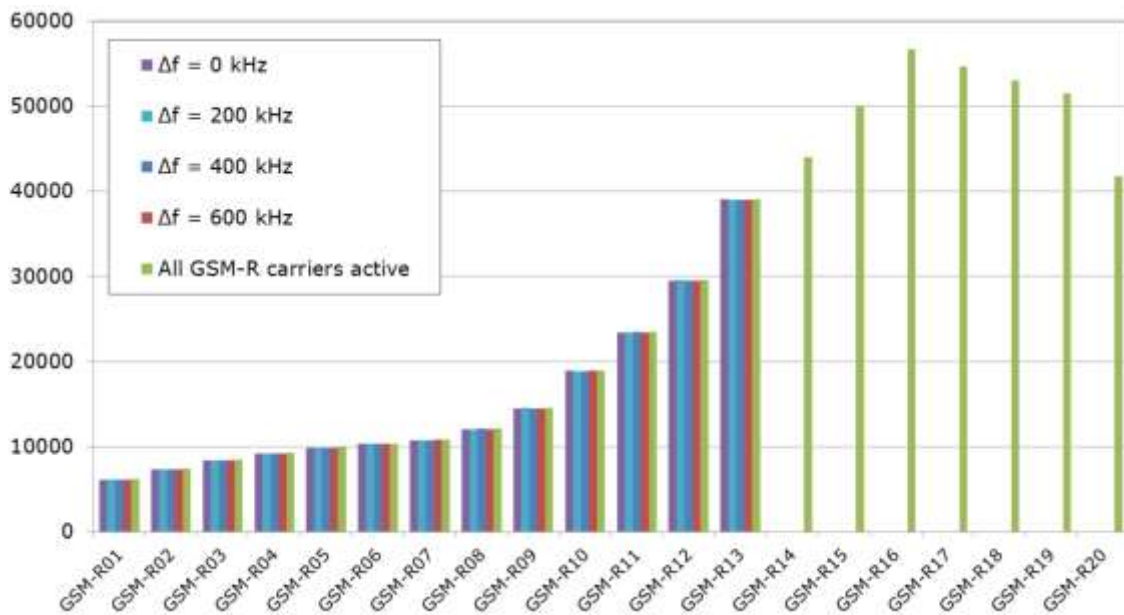

Figure 6-4: Possible IM3 products falling into the R-GSM-band when two GSM-R carriers or all GSM-R carriers are active

Once again, it is found that the number of products falling in a specific GSM-R carrier is only slightly increased compared to the calculation where one GSM-R carrier has been active. The chart further shows that a considerable number of products are also falling into the bandwidth occupied by the LTE carrier, with a peak slightly below the centre frequency of the LTE carrier bandwidth. A symmetrical shape of products around the LTE carrier is found with decreasing number of products above the centre frequency; therefore, also IM products falling into the bandwidth above the LTE carrier can be assumed which would need to be considered if the LTE carrier was located in the middle of the GSM-R bands.

### 6.3 Intermodulation Products falling in LTE Bandwidth

LTE uses S-OFDMA for the downlink and SC-FDMA for the uplink signal generation. In both cases for the signal generation a set of subcarriers separated by 15 kHz are used. So, IM products created by any pair of subcarriers will fall at subcarriers left and right of the pair. Figure 6-5 shows the resulting total number of IM3 products generated by the subcarriers falling into the 1.4 MHz LTE spectrum part under the assumption that all subcarriers are active. No further active carriers (e.g. like GSM-R carriers) have been considered:

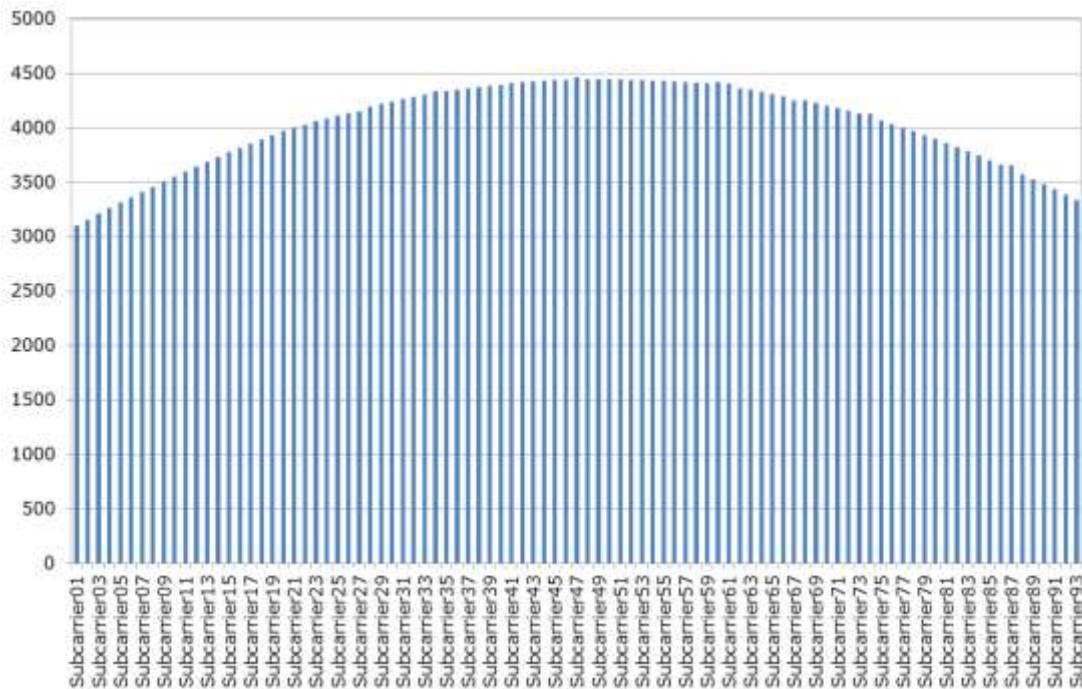

Figure 6-5: Possible IM3 products originating from LTE subcarriers

As can be observed from Figure 6-6 the total number of IM3 products is quite high and therefore a proper system design is necessary to prevent the LTE system from self-interference.

In a second step, also possible IM3 products falling into the LTE carrier bandwidth with two or all GSM-R carriers active have been determined. Like in the analysis for the GSM-R bandwidth, different guard bands  $\Delta f$  have been assumed and a separation of 400 kHz between the two GSM-R carries has been considered. Figure 6-3 below shows the resulting total number of IM3 products generated by the LTE subcarriers and two GSM-R carriers:

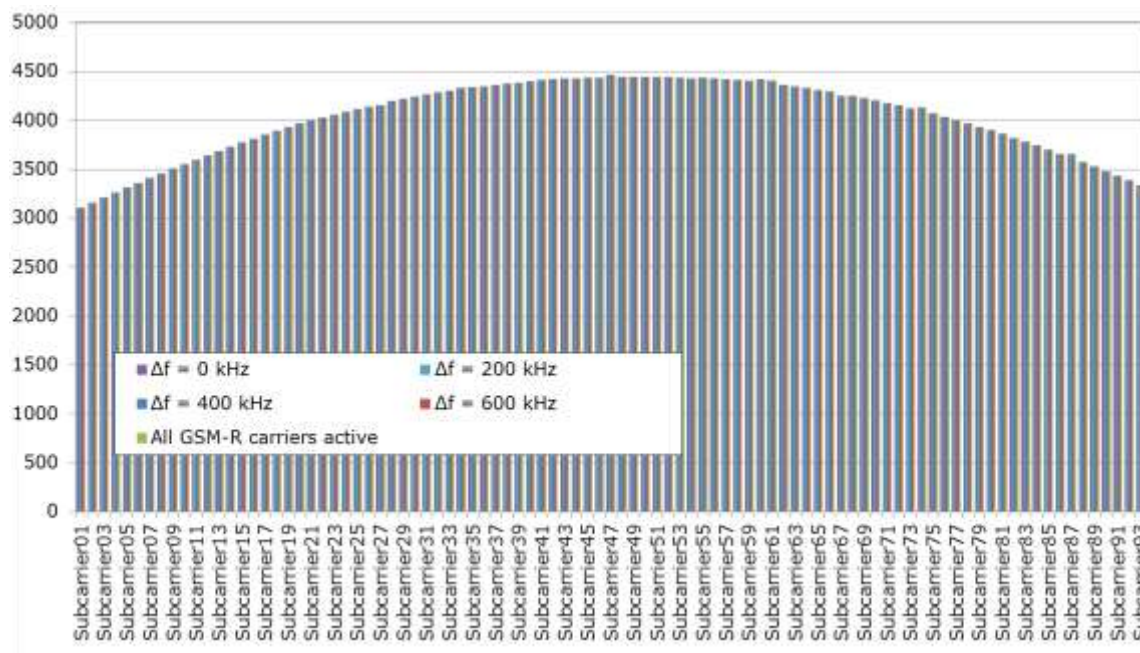

Figure 6-6: Possible IM3 products falling into the LTE carrier band when two GSM-R carriers or all GSM-R carriers are active

Figure 6-6 shows the same general shape of intermodulation products as found from the analysis without active GSM-R carriers in Figure 6-5. Thus, it is concluded that there is no major increase of intermodulation products due to the GSM-R carriers. A more detailed analysis showed, that in case that all GSM-R carriers would be active at the same time, in total approximately 450 additional intermodulation products would fall into the LTE carrier bandwidth. Thus, the products would likely only affect selected subcarriers.

## 6.4 Summary

Receiver produced intermodulation effects occur when two or more transmitter signals are mixed at non-linear components in the receiver chain. GSM-R MS are very sensible to intermodulation interference, as they need to be capable to operate in frequency bands dedicated for railway use as well as in frequency bands used by public mobile networks. In consequence, interference due to receiver intermodulation has been observed in existing GSM-R networks for example between public mobile networks and GSM-R. Different studies like report FM(13)134 [5] and ECC Report 229 [6] describe intermodulation interference in GSM-R downlink due to LTE. Measurements done in UK showed problems in GSM-R downlink due to intermodulation with UMTS ([7], [8]).

Thus, interference due to intermodulation might also be found in the analysed sharing scenarios, where a LTE carrier is operated within the band dedicated for GSM-R.

The theoretical analysis of intermodulation effects focused on IM3 products and evaluated the number of IM products falling in relevant receive bands to gain general insight to possible intermodulation effects. The determination of powers of intermodulation product would require detailed knowledge of the receiver structure, and calculation of bandwidth of the intermodulation products, and has therefore not been done.

The following scenarios have been analysed:

- One LTE 1.4 MHz carrier without any further GSM-R carriers active.

- One LTE 1.4 MHz carrier and one active GSM-R carrier operated with guard bands  $\Delta f$  in a range from 0 - 600 kHz
- One LTE 1.4 MHz carrier and 2 active GSM-R carriers with guard bands  $\Delta f$  in a range from 0 - 600 kHz between LTE and the first adjacent GSM-R carrier. A spacing of 400 kHz between the two GSM-R carriers has been considered.
- One LTE 1.4 MHz carrier and all remaining GSM-R carriers of the R-GSM band active at the same time. This is obviously a hypothetical scenario that allows assessing all possible carrier combinations in a worst case scenario, as the number of IM products of different carrier combinations sums up and thus are included in the calculation result.

As a result of the analysis, both IM3 products falling into GSM-R carrier bandwidth as well as IM3 products falling into the LTE carrier bandwidth have been identified.

The following tendencies have been derived for IM3 products falling into the GSM-R receive bandwidth:

- The major part of intermodulation products results from interaction of LTE subcarriers with themselves without further interaction with GSM-R carriers; this applies to intermodulation products falling on GSM-R carriers as well as for products falling in the LTE carrier bandwidth.
- The number of intermodulation products falling into a specific GSM-R carrier decrease the further apart the considered carrier is from the LTE carrier.
- The number of intermodulation products changes only slightly with the guard band  $\Delta f$  between the LTE carrier and the GSM-R carrier active in the calculation.
- The highest number of intermodulation products falling in the receive band for a specific GSM-R carrier is found, if the carrier itself has been active in the calculation.
- Including a second GSM-R carrier into the calculation results only in a minor increase of additional intermodulation products.
- A symmetrical shape of IM products around the LTE carrier is found with decreasing number of products above and below the centre frequency.

Given the possibility of IM products causing additional interference in cases of GSM-R/LTE coexistence, it would be beneficial, if not essential, that all GSM-R receivers met the requirements identified in ETSI TS 102 933.



## 7 Laboratory Tests

The scope of the laboratory tests was to analyse and verify the performance of GSM-R and LTE in band sharing situations with measurements and to broaden and verify the results achieved from the sharing analyses. The measurements have been performed at the Laboratory of the Faculty of Transportation Science, Chair of Transport Systems Information Technology at the Dresden University of Technology.

### 7.1 Methodology

#### 7.1.1 Approach for Interference Measurements

The relevant interference mechanisms to be considered when GSM-R and LTE share the same frequency band depend on the frequency arrangement of the specific scenario. Typical interference mechanisms that could arise are:

- Desensitization of receiver due to interference power leaking at the band edges from GSM-R and the new technology due to out of band emissions
- Interference due to intermodulation products resulting from non-linear effects at the receiver
- Signal degradation due to receiver blocking effects.

Technology standards typically define minimum performance criteria separately for different interference effects (e.g. for blocking performance, intermodulation suppression etc.) and thus are separately analysed during sharing calculations in compatibility studies. In a real system however the effects will occur simultaneously, thus during the laboratory tests it is not necessary to do separate analyses for different interference effects to determine if compatibility is given or not.

We therefore found that a generic interference model would need to be used and the system performance needs to be analysed with measurements, the used model consists of the interfered system (wanted transmitter, wanted link and receiver) and the interfering transmitter that affects the transmitter via the interfering link:

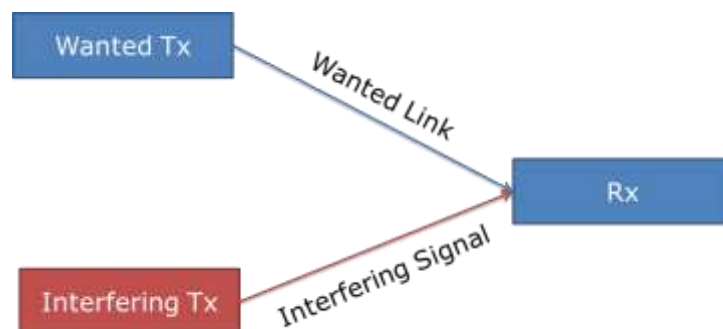

Figure 7-1: Generic interference model

The following chart depicts the different metrics for a scenario where LTE is interfering a GSM-R connection:

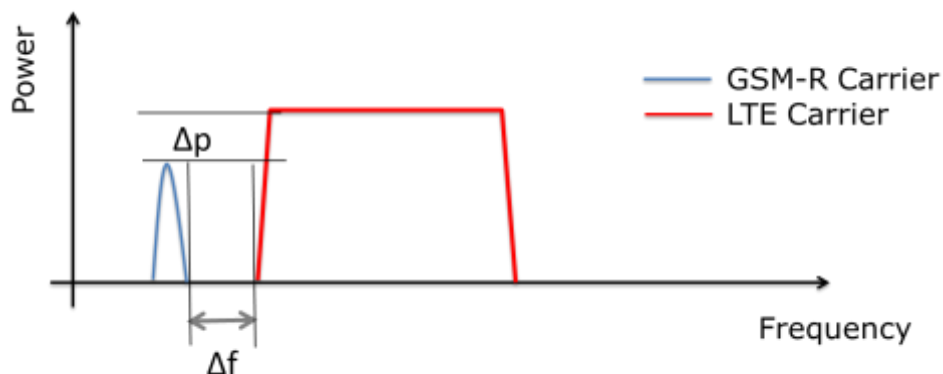

Figure 7-2: Interference scenario

With this model, the impact of the interfering signal generally depends on the following parameter:

- The frequency separation  $\Delta f$  between the GSM-R signal and the LTE signal
- The absolute level of wanted Signal  $R_{x_W}$
- The power difference of the wanted and the interfering signal  $\Delta p = R_{x_I} - R_{x_W}$

The interfering signal could cause different interference effects (e.g. desensitization, intermodulation, blocking) depending on the power difference  $\Delta P$  and the absolute receive level of the wanted signal  $R_{x_W}$  which would decrease the link quality.

Therefore, during the measurements, the degradation of the link quality with increasing  $\Delta p$  has been determined for different parameter settings and the following indicators for link quality have been determined:

- For GSM-R the Bit Error Rate (BER) and the corresponding RxQual
- For LTE the Bit Error Rate (BER) and the reduction in throughput

During a review of different documents, we found that there seems to be no common view about a minimum RxQual level that is required for satisfying GSM speech services. Table 7-1 gives a number of references that we identified during our research:

RxQual Criteria	Source
RxQual $\leq 5$	ECC REPORT 118 „Monitoring methodology to assess the performance of GSM networks“
RxQual $\leq 4$	ECC Report 229 „Guidance for improving coexistence between GSM-R and MFCN in the 900 MHz band“ ECC Report 231 “Mobile coverage obligations” FM(13)134_GSM-R Measurement Report - BNetzA Germany Red M / Ofcom Report “UMTS 900 - GSM-R Interference Measurements”
RxQual $\leq 3$	GSM-R Radio Planning Guidelines JBV Utbygging GSM-R / Norwegian Railways
RxQual $\leq 2$	ECC Report 200 „Co-existence studies for proposed SRD and RFID applications in the frequency band 870-876 MHz and 915-921 MHz“

Table 7-1: References for RxQual criteria

According to our partner from German Railways, in Germany a criteria for site acceptance is used, where for at least 90% of the track the measured RxQual need to be smaller than 4 before the site is accepted. This corresponds to the requirement  $RxQual \leq 3$  used in the Norwegian GSM-R Planning Guidelines.

Therefore, a criterion of  $RxQual \leq 3$  has been used to analyse the measurement results.

For assessment of LTE throughputs a reduction of 5 % has been assumed, as also is used in the blocking definitions of the 3GPP standards.

### 7.1.2 General Measurement Setup

The following figure shows the used measurement setup with the main components:

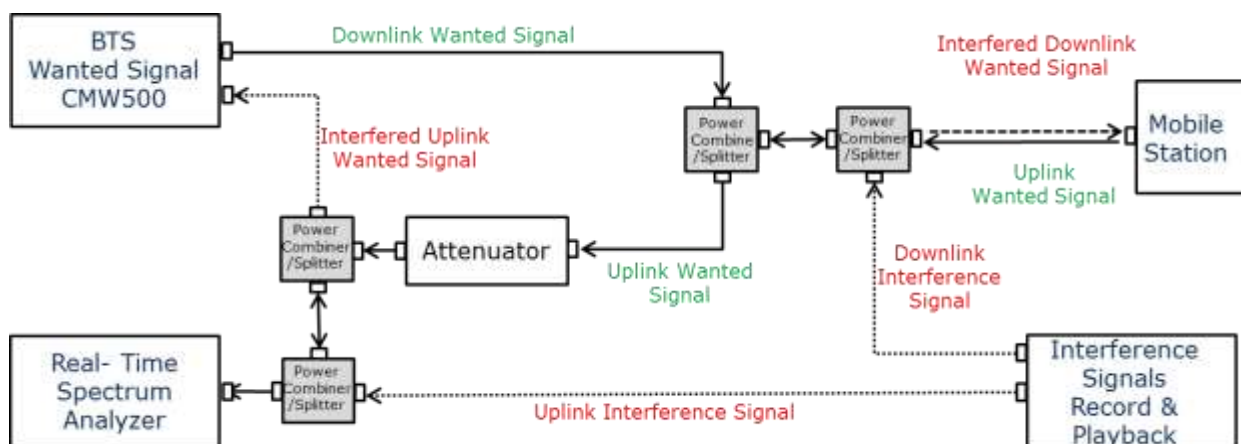

Figure 7-3: Measurement setup

The measurement setup consists of the following main components:

Logical function in setup	Device
Base station simulator (wanted link)	R&S CMW500 universal tester
Mobile station (MS) for GSM-R	Sagem NNG GPH-99 (with antenna dock modification)
Mobile station (UE) for LTE	Samsung Galaxy S5 Mini (with antenna dock modification)
Base station and user equipment for interfering link	Averna multichannel RF Record & Playback system URT RP-3200
Spectrum measurement and visualization	R&S FSVR 7 real time spectrum analyser

Table 7-2: Elements of measurement setup

The Rohde&Schwarz CMW500 universal tester is an all-in-one test platform for wireless communication, supporting the simulation of a GSM-R base station and an LTE Evolved Node B. The CMW 500 has been used as base station simulator for the wanted link. It has further used to validate the quality of the signal links.

A multichannel wideband RF Record & Playback system URT RP-3200 from Averna has been used to record and generate the interfering signals. With this system, real LTE and GSM-R uplink and downlink signals have been recorded separately on two channels with 5 MHz bandwidth using an interfered link between the CMW 500 and the corresponding user

equipment. The Record & Playback system allows varying power and frequency of the replayed system while maintaining the spectral and temporal variations of the original system and therefore allows flexible simulation of the different scenarios.

As GSM-R Mobile Station a SAGEM NNG GPH 940 GSM-R mobile device provided by German Railways has been used.

Currently there is no LTE equipment available that would support the ER/R-GSM band. Therefore, a Samsung Galaxy S5 Mini has been selected as this model supports LTE Band 8 that is directly adjacent to the R-GSM band. This model further allows for the installation of an antenna dock, which is necessary for a cabled RF connection.

Also for the SAGEM MS modifications have been done to allow for a cabled RF connection:

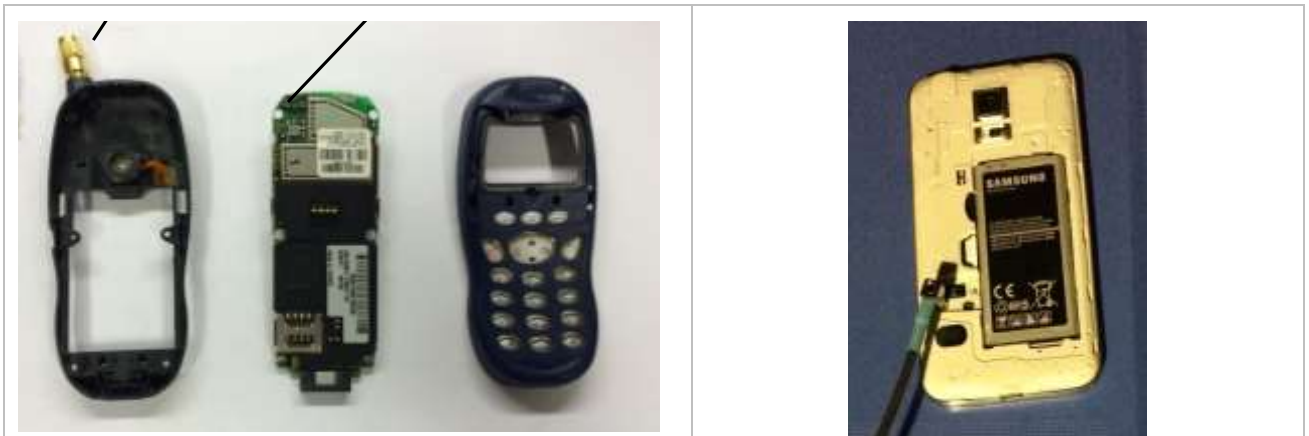

Figure 7-4: GSM-R MS (Sagem NNG GPH-99, left) and LTE User Equipment (Samsung Galaxy S5 Mini, right) with antenna dock modification

The R&S FSVR 7 real time spectrum analyser has been used for different measurement tasks like spectrum visualization. The analyser supports visualizing how frequently signals occur to display spectrum variation over time (persistence mode).

Furthermore, measurements were developed and installed in the semi-anechoic chamber at Chair of Transport Systems Information Technology:

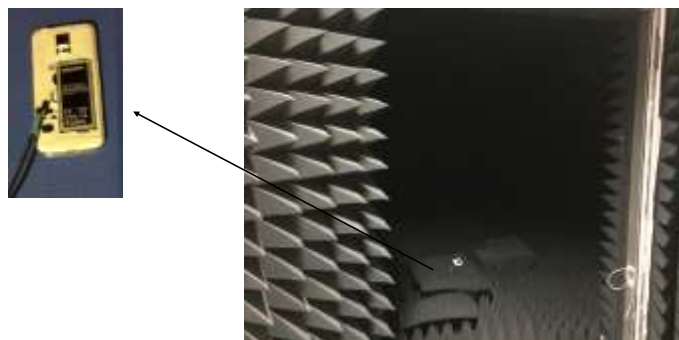

Figure 7-5: Anechoic chamber and mobile device

## 7.2 GSM-R interfered by LTE

### 7.2.1 Equipment configuration

To evaluate the impact of a 1.4 MHz LTE carrier on GSM-R, the CMW 500 has been configured to operate as GSM-R test generator. For this, the "Burst-by-Burst" mode with Loop-C configuration of the R&S CMW has been used that transmits test bits (Pseudo Random Binary Sequence PRBS-15) without error protection (class II bits). The mobile station RX receives the test sequence via the downlink, loops it internally to the MS TX, and returns the data via the uplink to the CMW 500. The CMW 500 compares the sent and received bit sequences and determines the BER and the corresponding RxQual. (Loop C).

The Averta R&P system has been used to replay a 1.4 MHz carrier in uplink and downlink with the following parametrization:

- LTE Downlink: 64 QAM, TBSidx 21, TBS 2984, code rate  $\frac{3}{4}$ , 6 resource blocks
- LTE Uplink: 16 QAM, TBSidx 19, TBS 2600. code-rate  $\frac{1}{2}$ , 6 resource blocks

The receive level of the wanted and the interfering level as well as the guard band has been varied during the measurements. Downlink and uplink has been interfered at the same time as it would be in a real network. For a given wanted signal level and guard band, the interfering power has been increased until the link has been lost (missing sync) or the power limitation of the available system has been reached.

### 7.2.2 Measurement Results

Figure 7-6 shows measurement results of the BER over different values for interfering power  $\Delta p$  in downlink. The wanted receive level in downlink has been set to -93 dBm. The interfering power has been increased until the BER reached a value of 100% or the connection has been lost due to missing synchronization. Measurements have been done for guard bands of  $\Delta f = 0$  kHz, 200 kHz and 400 kHz:

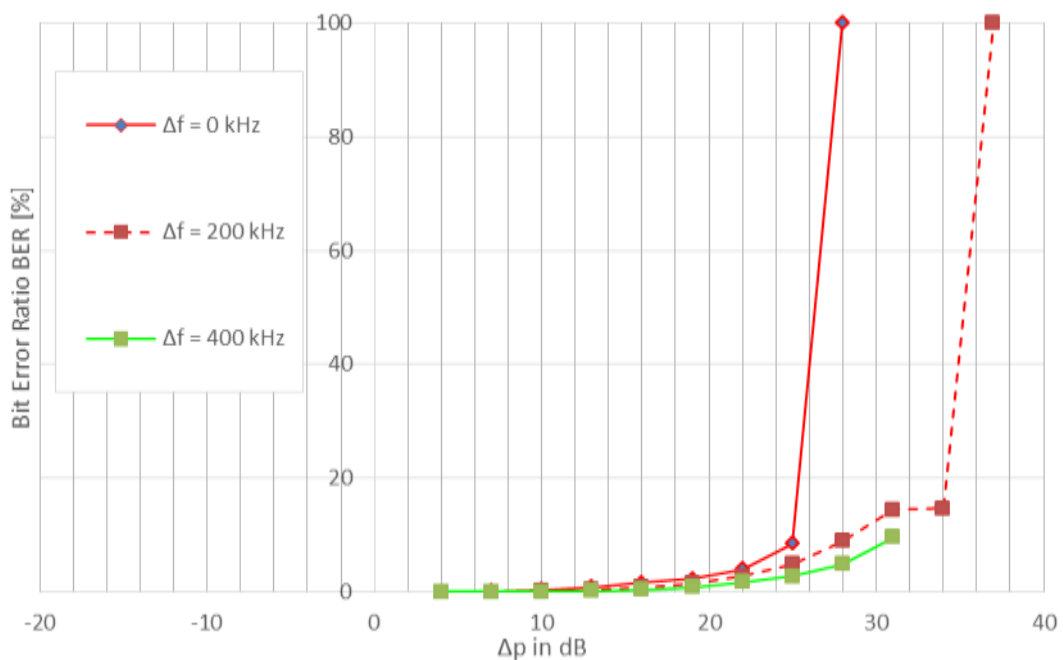

Figure 7-6: BER over downlink  $\Delta p$

For a wanted receive level in downlink of  $R_{x_W} = -93$  dBm it has been found that for LTE powers up to  $\Delta p = 7$  dB above the GSM-R signal level (measured over the LTE carrier bandwidth at the GSM-R MS RX connector) no significant increase in the GSM-R downlink BER could be observed. With further increasing the LTE power, an increase in the downlink BER and the corresponding RxQual has been found. The following table gives an overview on the observed RxQual in dependence of  $\Delta p$ :

$\Delta p$	$\Delta f = 0$ kHz	$\Delta f = 200$ kHz	$\Delta f = 400$ kHz
4 dB	0	0	0
7 dB	0.07	0.01	0
10 dB	0.27	0.06	0.01
13 dB	0.7	0.26	0.05

Figure 7-7: Measured BER in dependence of downlink  $\Delta p$

Please note, that the given BER figures have been derived without the impact of any error correction methods that might be applied on later stages of the receiver. From the results, the measurements indicate that un-interfered data transmission is feasible as long as  $\Delta p$  does not exceed a value of 4 dB.

Figure 7-8 shows the corresponding RxQual values:

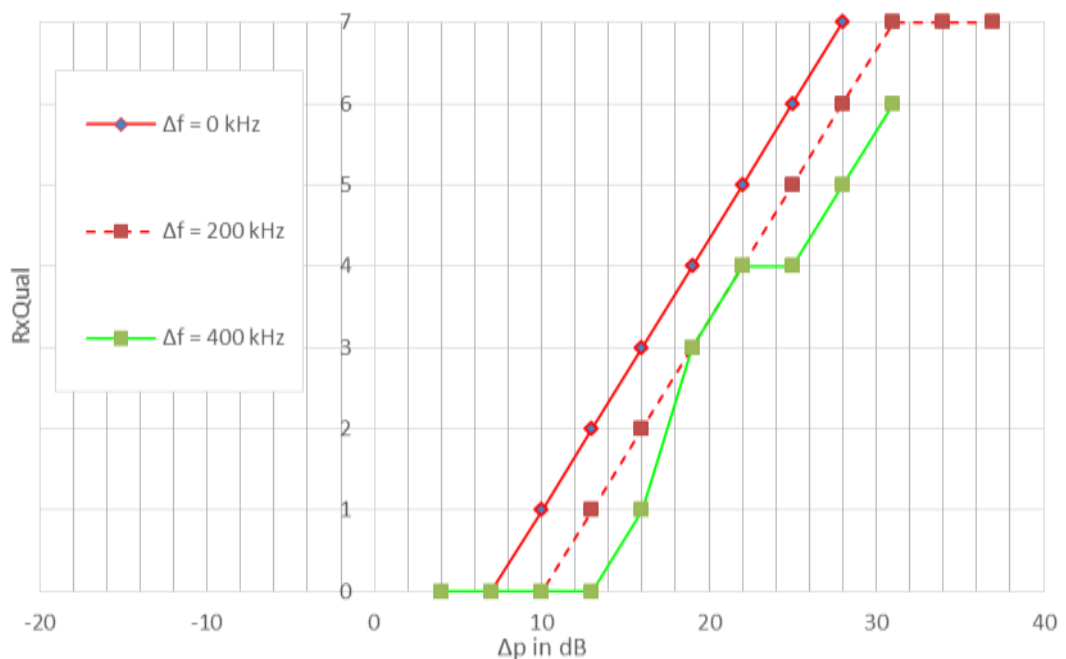

Figure 7-8: RxQual over downlink  $\Delta p$

The figures for  $\Delta f = 0$  kHz and  $\Delta f = 200$  kHz show the expected behaviour, where an increase in  $\Delta f$  results in an increased level of interference that can be tolerated before a critical BER or RxQual is found. Assuming that RxQual should not exceed 3, it is found that for  $\Delta f = 0$  kHz this value is found at  $\Delta p = 19$  dB, while for  $\Delta f = 200$  kHz interfering levels up to  $\Delta p = 22$  dB can be tolerated. An offset of additional 3 dB of interfering level with increasing 200 kHz for  $\Delta f$  is observed. An interesting result has been observed for the case of  $\Delta f = 400$  kHz, where the line

for RxQual shows the expected 3 dB offset for small RxQual figures, but then approximates the line for  $\Delta f = 200$  kHz before it goes back to a line with 3 dB offset to the one for  $\Delta f = 200$  kHz. During the measurement, no RxQual of 7 could be measured in this case as the analysed radio link lost sync before RxQual 7 has been reached. This behaviour could be reproduced in several independent measurements.

Further measurements at a wanted levels  $R_{x_W} = -70$  dBm,  $-35$  dBm and  $-25$  dBm for GSM-R have been performed.

The following table gives the  $\Delta p$  for different values of  $R_{x_W}$  and  $\Delta f$ , where a value of RxQual=4 has been reached and thus the RxQual requirement of  $RxQual \leq 3$  has no longer been met. Values marked with ">" indicate measurements where RxQual stayed always below 4 as the interfering power could not be further increased due to the dynamic range of the measurement setup:

DL Signal	$\Delta f = 0$ kHz	$\Delta f = 200$ kHz	$\Delta f = 400$ kHz
$R_{x_W} = -93$ dBm	19 dB	22 dB	22 dB
$R_{x_W} = -70$ dBm	> 14 dB	> 14 dB	> 14 dB
$R_{x_W} = -35$ dBm	5 dB	> 15 dB	-
$R_{x_W} = -25$ dBm	> 5 dB	> 5 dB	-

Table 7-3:  $\Delta p$  for different downlink configurations where RxQual exceeds 3

Thus, taking a quality requirement of  $RxQual \leq 3$  and the measurement results from the table above into account, we conclude that, for levels  $R_{x_W}$  up to  $-35$  dBm, a sufficient connection quality could be achieved if, for guard bands of at least 200 kHz, the carrier power of the LTE carrier, measured at the antenna connector of the GSM-R MS, is not more than approximately 14 dB above the wanted level of the GSM-R connection. For receive levels in a range from  $-35$  dBm up to  $-25$  dBm, the margin might be smaller but would not fall below 5 dB.

Simultaneous to measurements in downlink, also measurements in uplink have been performed. The following table gives the  $\Delta p$  for different values of  $R_{x_W}$  and  $\Delta f$  where a value of RxQual=4 has been reached thus the RxQual requirement of  $RxQual \leq 3$  has no longer been met. Values marked with ">" indicate measurements where RxQual stayed always below 4 as the interfering power could not be further increased due to the dynamic range of the measurement setup:

UL Signal	$\Delta f = 0$ kHz	$\Delta f = 200$ kHz	$\Delta f = 400$ kHz
$R_{x_W} = -80$ dBm	> 12 dB	> 21 dB	> 15 dB
$R_{x_W} = -35$ dBm	9 dB	> 15 dB	-

Table 7-4:  $\Delta p$  for different uplink configurations where RxQual exceeds 3

The table shows similar figures than found in the downlink. The results indicate that for a guard band of  $\Delta f = 200$  kHz a connection can be maintained with an  $RxQual \leq 3$  as long as  $\Delta p$  is not larger than approximately 15 dB.

However it need to be noted that, due to limitations in the dynamic range of the measurement setup measurements at very low levels for the wanted signal in uplink could not be performed.

## 7.3 LTE interfered by GSM-R

### 7.3.1 Equipment Configuration

To evaluate the impact a GSM-R signal on the throughput of a 1.4 MHz LTE carrier, the CMW 500 has been configured to operate as LTE test generator that sends and receives a LTE data stream. In downlink, the CMW 500 sends data to the UE via PDSCH subframes and requests the UE to confirm the correct reception. The UE confirms each received subframe with an ACK or NACK via the PUSCH. The R&S CMW calculates the DL BLER from the received ACKs and NACKs. It determines the CQI, PMI and RI results from the corresponding reported values. For the uplink, the R&S CMW performs a CRC check and calculates the UL BLER from the results of the check. For transmission schemes using several downlink streams, the ACKs, NACKs and CQI indices reported for the streams are evaluated separately. Throughput is calculated from the CRC Pass / Fail results and the maximum possible downlink/uplink throughput.

Measurements have been performed for the following LTE configurations:

- LTE Downlink with 6 resource blocks utilized
  - 64QAM, TBSidx 21, TBS 2984, code rate 3/4
  - 16QAM, TBSidx 16, TBS 1928, code rate 1/2
  - QPSK, TBSidx 6, TBS 600, code rate 1/3
- LTE Uplink with 6 resource blocks utilized
  - 16QAM, TBSidx 19, TBS 2600, code rate 1/2
  - QPSK, TBSidx 6, TBS 600, code rate 1/3

The Averta R&P system has been used to replay a GSM-R carrier in uplink and downlink with the following parametrization:

- GSM-R Downlink: BCCH carrier with 8 TS fully transmitted
- GSM-R Uplink: TCH carrier with 1 TS utilized

The receive level of the wanted and the interfering level as well as the guard band has been varied during the measurements. Downlink and uplink has been interfered at the same time, as it would be in a real network. For a given wanted signal level and guard band, the interfering power has been increased until the link has been lost (missing sync) or the power limitation of the available system has been reached.

### 7.3.2 Measurement Results

Figure 7-9 shows measurement results of the throughput in downlink over different values for interfering power  $\Delta p$ . The wanted receive level in downlink has been set to -100 dBm. The interfering power has been increased until a BER of 100% has been reached and the throughput has been decreased to 0. Measurements have been done for guard bands of  $\Delta f = 0$  kHz, 200 kHz and 400 kHz:



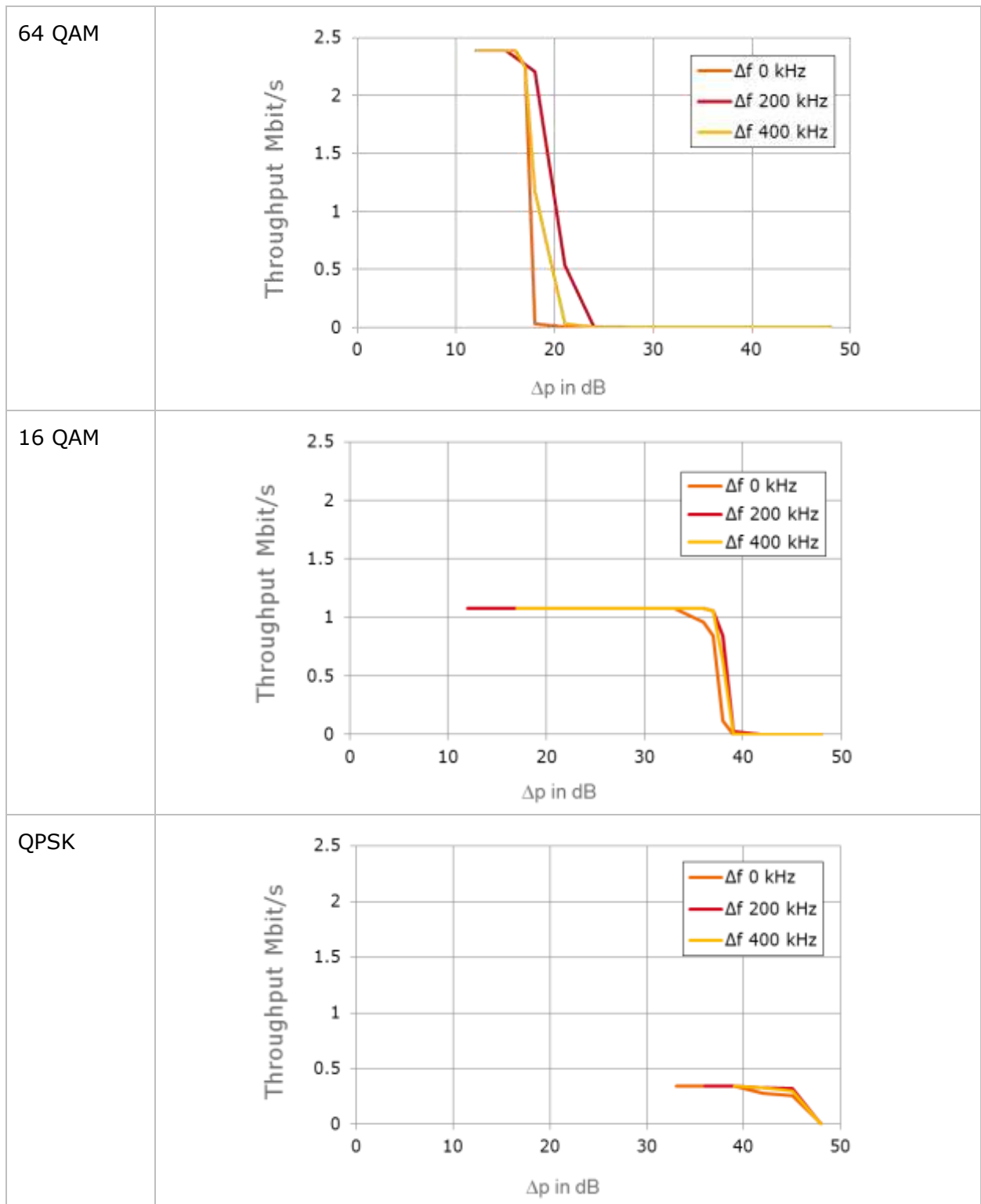

Figure 7-10: Downlink throughput over  $\Delta p$ ,  $R_{x_w} = -100$  dBm

A comparison of the results for the different modulation schemes shows the expected behaviour where QPSK and 16 QAM can handle higher  $\Delta p$  than the more complex 64 QAM. If a raw throughput of approximately 1 Mbit/s is assumed sufficient, the system could be used in

environments with  $\Delta p$  of up to approximately 35 dB before a degradation of the throughput could be observed. The results furthermore show only a rather small dependency from  $\Delta f$ , which can be understood from the rather sharp spectrum emission mask of the GSM-R system.

Additional measurements have been performed at higher levels for the wanted signal. Figure 7-10 shows the result for downlink, using 64 QAM at a wanted level of -70 dBm:

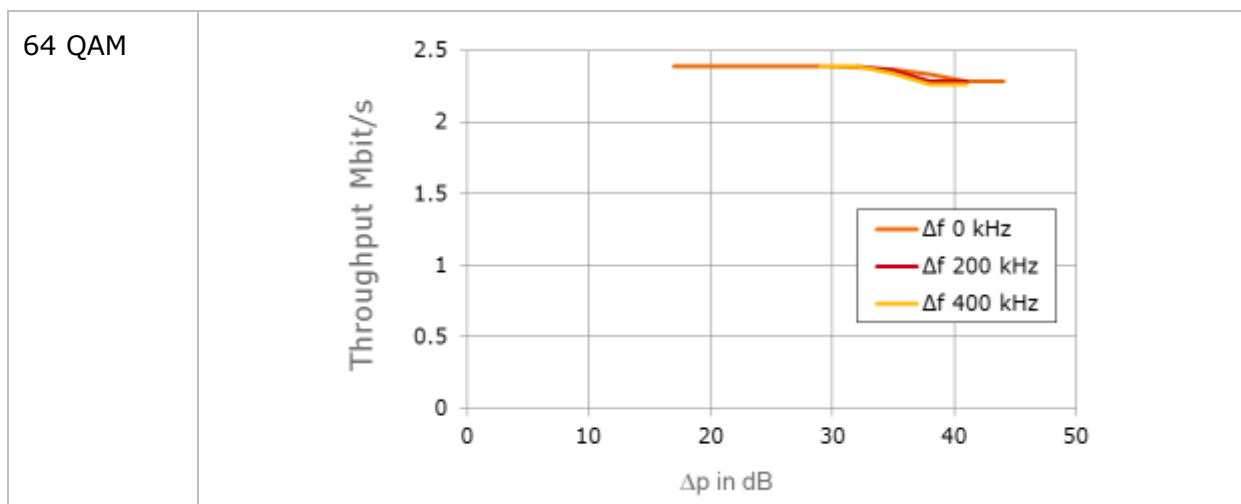

Figure 7-11: Downlink throughput over  $\Delta p$ ,  $R_{x_W} = -70$  dBm

The measurement shows, that with increasing level for wanted signals the system can support higher interfering levels. While for a wanted receive level of -100 dBm and  $\Delta f = 200$  kHz the reduction in throughput by 5% has been reached at a value of approximately 17 dB for  $\Delta p$ , a figure of approximately  $\Delta p=38$  dB is found for wanted signal levels of -70 dBm.

The following table summarizes the different values for  $\Delta p$  found during the measurements at which the throughput of the downlink has been reduced to 95% of the un-interfered value. Please note that values marked with (\*) have been derived by interpolation, as the measurement series did not include an exact value for a reduction of the throughput to 95 %:

DL Signal	$\Delta f = 0$ kHz	$\Delta f = 200$ kHz	$\Delta f = 400$ kHz
QPSK, $R_{x_W} = -100$ dBm	39.8* dB	44.1* dB	42.7* dB
16 QAM, $R_{x_W} = -100$ dBm	34.4* dB	37.2* dB	37.1* dB
64 QAM, $R_{x_W} = -100$ dBm	16.8* dB	16.9* dB	16.7 dB
64 QAM, $R_{x_W} = -70$ dBm	41 dB	38 dB	38 dB

Table 7-5:  $\Delta p$  for different DL configurations where throughput is reduced to 95%

For the analysed range of downlink receive levels at -100 dBm and -70 dBm it is found that the reduction of throughput remains below 5% as long as  $\Delta p$  is smaller than 17 dB for 64 QAM, 37 dB for 16 QAM and 44 dB for QPSK assuming a guard band  $\Delta f = 200$  kHz.

Figure 7-12 shows the results for measurements of the uplink throughput. The receive level during these measurements has been set to -82 dBm and, once again, the interfering level has been varied:

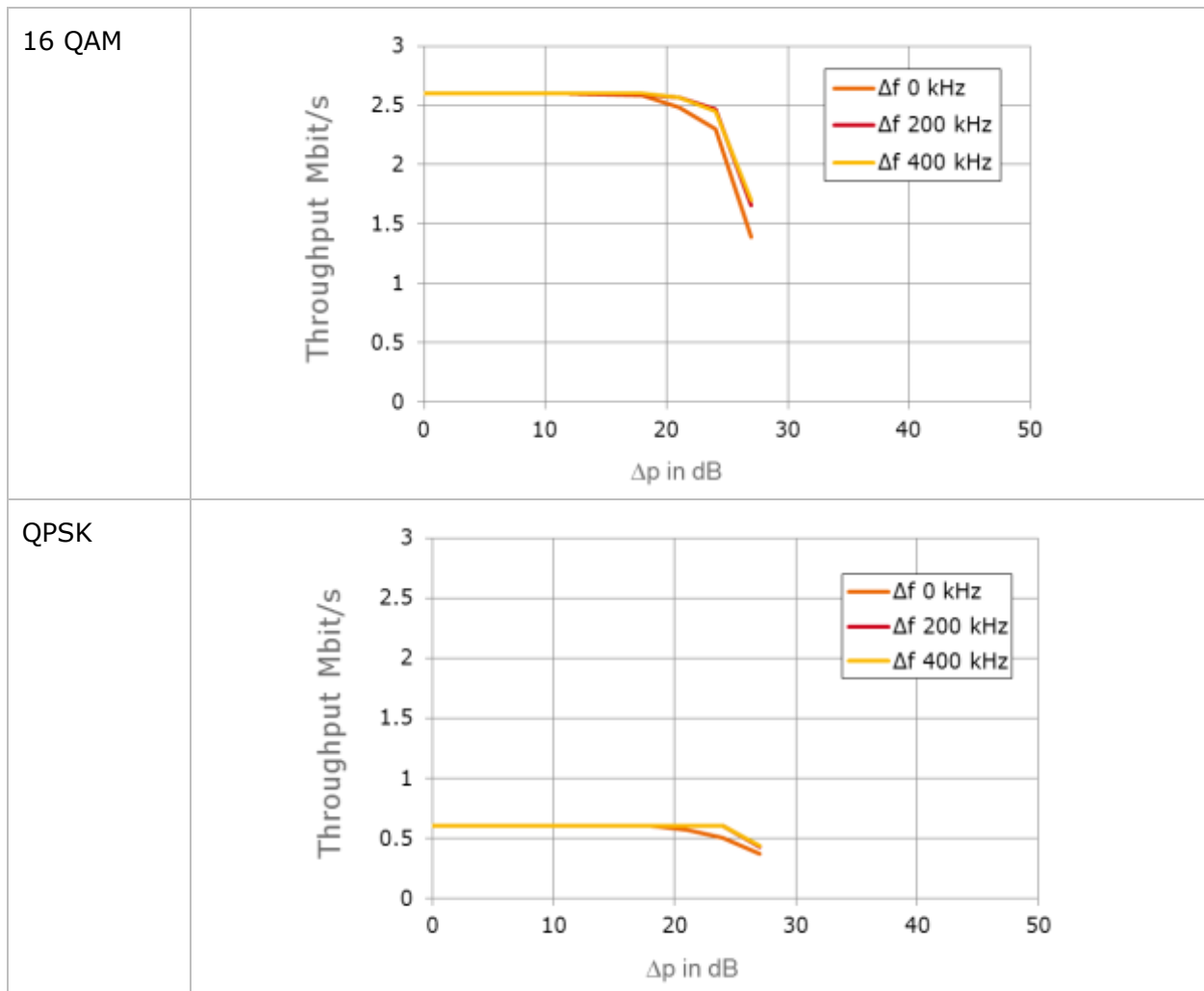

Figure 7-13: Uplink throughput over  $\Delta p$ ,  $R_{xW} = -82$  dBm

Based on the measurement results, it is found that the uplink is not affected, as long as  $\Delta p$  is not larger than approximately 20 dB. Comparing uplink with downlink measurements it appears that the uplink is more sensitive to the interference from GSM-R than the downlink, where QPSK has been affected for values of  $\Delta p$  approximately above 40 dB. Another interesting observation is that, for both modulation schemes, the decrease in throughput starts at approximately the same value for  $\Delta p$  around 20 dB. While this does not fit to the theory (and the results from the downlink, where QPSK has been more robust than 16 QAM), this effect has been observed and assured by TU Dresden during several measurements.

Additional measurements have been performed at higher levels for the wanted signal. Figure 7-14 shows the results for uplink using 16 QAM at a wanted level of -50 dBm:

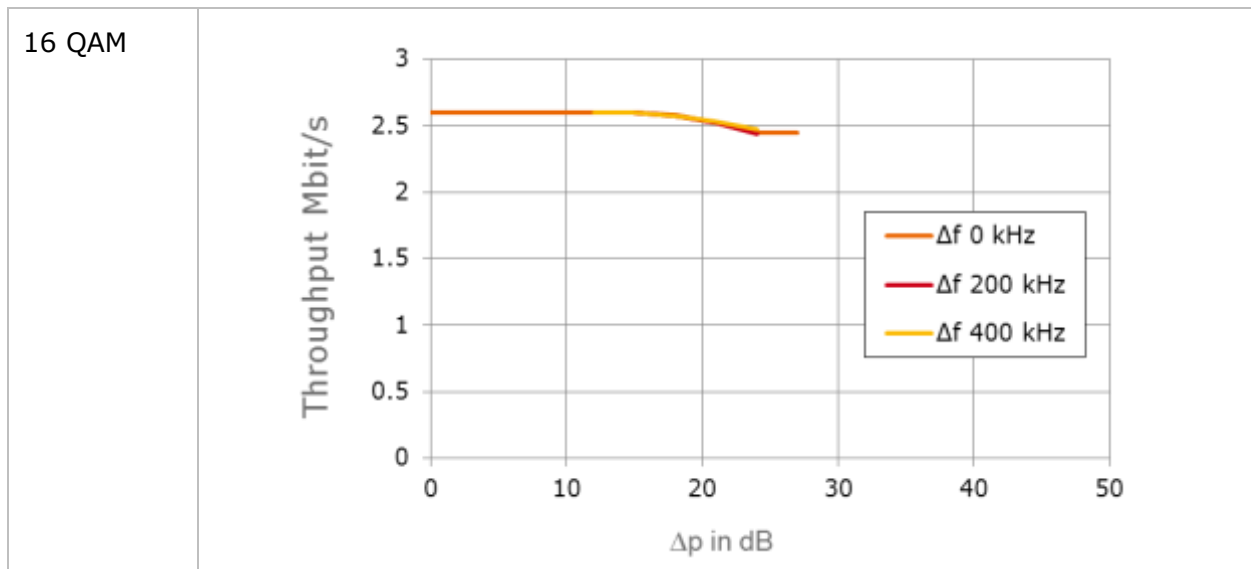

Figure 7-14: Uplink throughput over  $\Delta p$ ,  $Rx_w = -50$  dBm

The curves shows the same effect as found for lower levels of  $Rx_w$ : The reduction in throughput starts around levels of  $\Delta p=20$  dB, however, the degradation with increasing  $\Delta p=20$  is not as harsh as found for smaller  $Rx_w$ .

The following table summarizes the different values for  $\Delta p$  found during the measurements at which the throughput of the uplink has been reduced to 95 % of the un-interfered value. Please note that values marked with (\*) have been derived by interpolation, as the measurement series did not include an exact value for a reduction of the throughput to 95 %:

UL Signal	$\Delta f = 0$ kHz	$\Delta f = 200$ kHz	$\Delta f = 400$ kHz
QPSK, $Rx_w = -82$ dBm	21 dB	24.5* dB	24.5* dB
16 QAM, $Rx_w = -82$ dBm	21 dB	23.5* dB	21 dB
16 QAM, $Rx_w = -50$ dBm	21 dB	22.8* dB	24 dB

Table 7-6:  $\Delta p$  for different UL configurations where throughput is reduced to 95 %

The table reveals the same result as found during the discussion of the chart: The critical  $\Delta p$  where the throughput is reduced to 95 % is almost the same for all analysed cases. Assuming a guard band of  $\Delta f = 200$  kHz, a critical value of approximately  $\Delta p = 22$  dB is found.

## 7.4 Summary of Laboratory Tests

To assess the performance of GSM-R in the presence of a 1.4 MHz, carrier measurements in uplink and downlink have been performed to determine acceptable interference levels to maintain a signal quality of  $RxQual \leq 3$ . Measurements in GSM-R downlink have been performed in a range from -93 dBm up to -35 dBm for the wanted signal, while in uplink measurements have been done for wanted receive levels of -80 dBm and -35 dBm. The measurement yielded the following results for guard bands  $\Delta f$  of at least 200 kHz:

- In downlink, the quality requirement of  $RxQual \leq 3$  can be met if the carrier power of the LTE carrier is not more than approximately 14 dB above the wanted level of the GSM-R connection. For higher receive levels up to -25 dBm the margin might be smaller but would not fall below 5 dB.
- In uplink, similar figures have been found. The results indicate, that for a guard band of  $\Delta f = 200$  kHz a connection can be maintained with  $RxQual \leq 3$  if  $\Delta p$  does not exceed values of approximately 15 dB. However it need to be noted that, due to limitations in the dynamic range of the measurement setup, evaluations at very low levels for the wanted signal in uplink could not be performed.

Additional measurements have been performed for a 1.4 MHz LTE carrier to assess the reduction in throughput due to interference from an adjacent GSM-R carrier. Measurements in downlink have been performed for QPSK, 16 QAM and 64 QAM configurations at receive levels of -100 dBm. Additional measurements for 64 QAM have been performed for receive levels of -70 dBm. In uplink measurements have been performed for receive levels of -82 dBm (QPSK and 16 QAM) and -50 dBm (16 QAM). The following results have been found for guard bands  $\Delta f$  of at least 200 kHz:

- For downlink receive levels at -100 dBm the reduction of throughput remains below 5 % as long as  $\Delta p$  is smaller than 17 dB for 64 QAM, 37 dB for 16 QAM and 44 dB for QPSK. With increasing level of the wanted signal, the system supports higher levels of interfering power as measurements for 64 QAM at wanted receive levels of -70 dBm resulted in an acceptable  $\Delta p$  of approximately 38 dB.
- The measurement results for uplink shows that the reduction in throughput remains below 5 % as long as  $\Delta p$  is not larger than approximately 22 dB. Thus comparing uplink with downlink measurements it appears, that the uplink is more sensitive to the interference from GSM-R than the downlink where QPSK has been affected for values of  $\Delta p$  approximately above 40 dB. Another interesting observation is, that for both modulation schemes the decrease in throughput starts at approximately the same value for  $\Delta p$  around 20 dB. While this does not fit to the theory (and the results from the downlink, where QPSK has been more robust than 16 QAM), this effect has been observed and assured by TU Dresden during several measurements.

## 8 Network Simulations

The scope of the network simulations was to determine the impact of the different sharing scenarios and the introduction of an additional radio communication system on aspects like network structure, network coverage, required and achievable frequency reuse etc., and to assess requirements for site spacing in regard to their impact on network structure.

For this, we modelled a part of a GSM-R and LTE network around Leipzig main station within radio network planning software.

Leipzig main station (Leipzig Hauptbahnhof) is a dead-end station with 19 over-ground long distance platforms. In addition, two under-ground platforms in the City-Tunnel are providing access to trains. Within Europe only Frankfurt, Munich and Zürich Main Stations and the Paris' Gare du Nord and Gare de L'Est have more platforms. Measured by floor area, Leipzig main station is the world's largest dead end railway station.

The following shows an overview on the tracks at Leipzig main station:

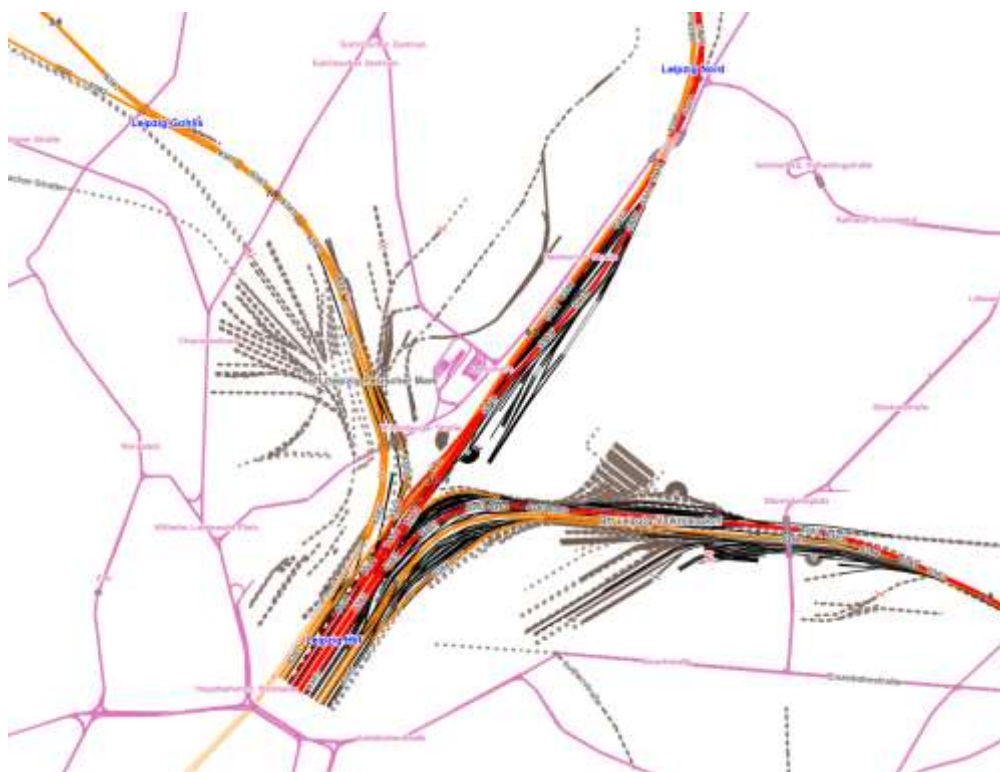

Figure 8-1: Tracks at Leipzig Main Station (Source: Openrailwaymap.org)

In total, three different networks have been modelled for Leipzig main station and the surrounding area with a radius of 20 km<sup>2</sup>:

- The existing GSM-R network based on site and channel usage data as provided by German Railways
- A LTE network that uses the same sites and antennas as the GSM-R network, however the LTE antennas have been mounted 1 m below the GSM-R antennas
- A new hypothetical LTE network covering the main tracks. Starting point for the new LTE network has been the GSM-R base station at Leipzig main station. Further stations have

been placed along the track at distances necessary to cover the track with minimum required data rates.

The analysis of the different networks is found in the ongoing sections.

## 8.1 Existing GSM-R Network

### 8.1.1 Coverage and C/I for existing Network (Baseline)

The network used for the analysis consists of sites in a radius of 20 km around Leipzig main station. The network is characterized by the following:

- The analysed network comprises in total 34 different sites
- With 28 sites, the major part of the sites uses two sector antennas to cover the track. The antennas are fed by the same BTS via a power splitter, thus these antennas use the same frequencies and build therefore the same cell.
- 6 sites are equipped with two BTS to build two cells, using individual frequencies from the same mast. This includes the BTS at Leipzig main station where one BTS is used to cover the tracks on the surface while a second BTS is used to cover the subterranean tracks.
- The sites use 19 carriers from the R-GSM-band. ER-GSM frequencies are not used.
- 30 cells use one carrier frequency (TRX) while 5 cells are equipped with 2 TRX. This includes an indoor coverage system for the subterranean parts of Leipzig main station (City tunnel) where an indoor coverage system is employed that uses that individual frequencies that are different from the ones used to cover the surface parts of the station.

Figure 8-2 shows the resulting coverage, not all sites are shown as some are lying outside the window used for the charts. These sites are not shown, however their impact has been considered in the calculations.

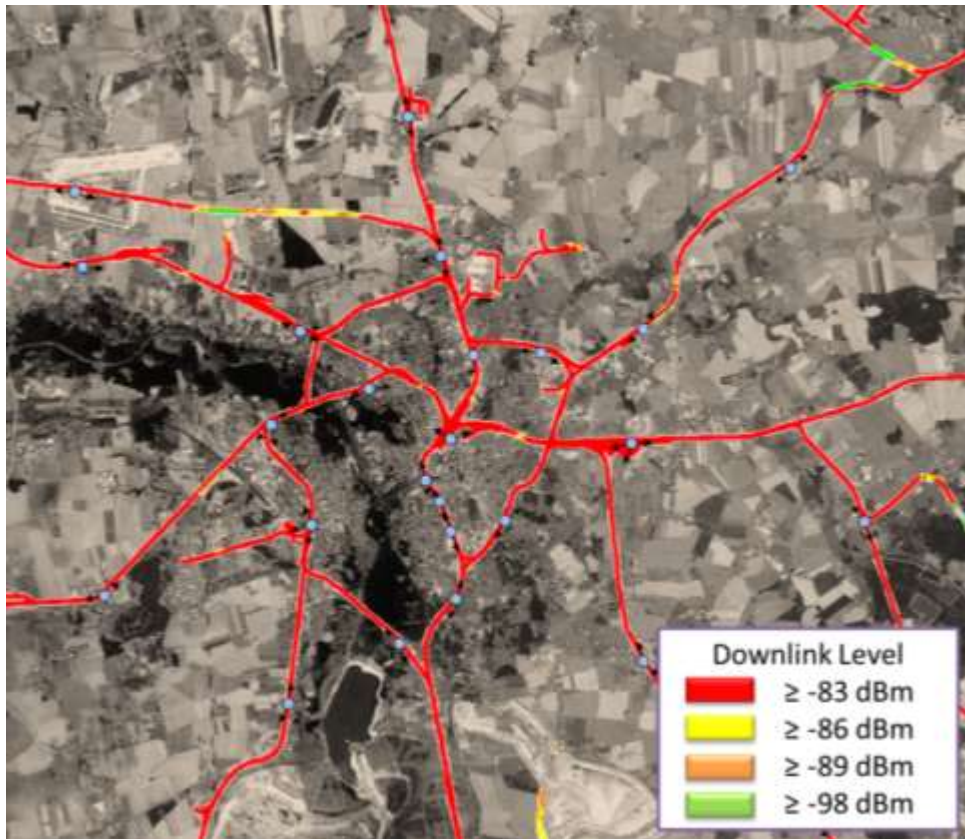

Figure 8-2: Overview on network in area of Leipzig main station

In total 18 different channels from the R-GSM band are used. The following chart indicates the frequency re-use in the network:

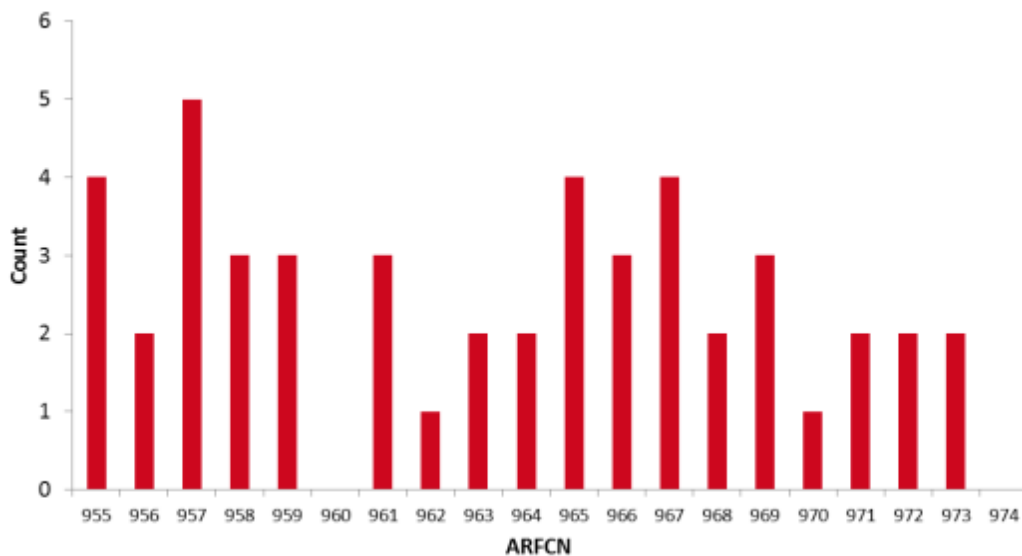

Figure 8-3: Channel re-use GSM-R (as is)



The resulting C/I within the network is displayed in Figure 8-4:

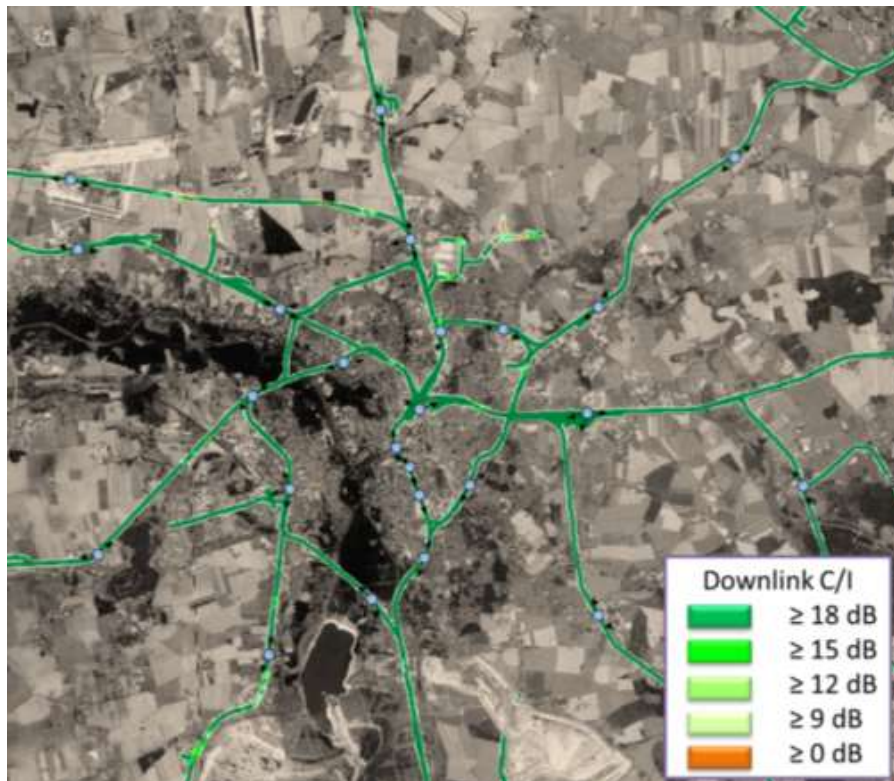

Figure 8-4: Downlink C/I for existing channel assignment

The C/I plot shows that in the relevant parts of the network along the tracks the C/I is far above the requirement of 9 dB coming from the GSM standard. However, it needs to be noted that the field strength calculations results in mean values for the downlink receive level. In the field both the level of the wanted signal as well as the level of the interfering signal will vary around this mean value due to shadowing and fading effects. Thus, typically a margin of several dB is considered while assessing the C/I in the planning software to ensure that the C/I criteria of at least 9 dB is achieved in the field. With typical margins in a range of up to 10 dB C/I, planning criteria of up to 20 dB are found. Even such increased C/I requirements are met by the analysed network.

### 8.1.2 Analysis of Channel Requirements for existing Network

The introduction of a LTE carrier with a bandwidth of 1.4 MHz would block at least 7 GSM-R carriers plus the required guard bands. In order to assess the impact of such a reduction of the available frequency band for GSM-R we analysed how many carriers are needed to create a frequency plan with a specific quality. For this we calculated an interference matrix and interference relations table with our planning software that holds for each possible cell relation the probability that interference might occur in case that the two considered cells would use the same (co-) or adjacent channel (what-if analysis). This cell relations table can be used by a frequency assignment algorithm to assign frequencies to the network. For this, a threshold for the maximum permissible interference probability inside the network can be defined. The algorithm then assigns frequencies to sites from the available frequency band in a way that the interference probability in the network does not exceed the threshold. Based on the interference relations table the tool can also determine the minimum number of carrier frequencies that are at least required to plan the network.

The number of carrier frequencies required by the network depends on the following:

- The interference relations between cells (which are dependent on the network structure, site parameter and terrain) and the allowed permissible interference
- The handover relations defined for the network, as a GSM-R MS cannot handover between two cells having the same or adjacent carriers.

Dependant on the network structure and the permissible interference as well as the defined handover relations sometimes the required number of carriers could either be limited by the interference relations or by the number of handover relations.

This can be seen from Figure 8-5 that shows the required number of channels for the network around Leipzig main station in dependence of different thresholds for the permissible interference:

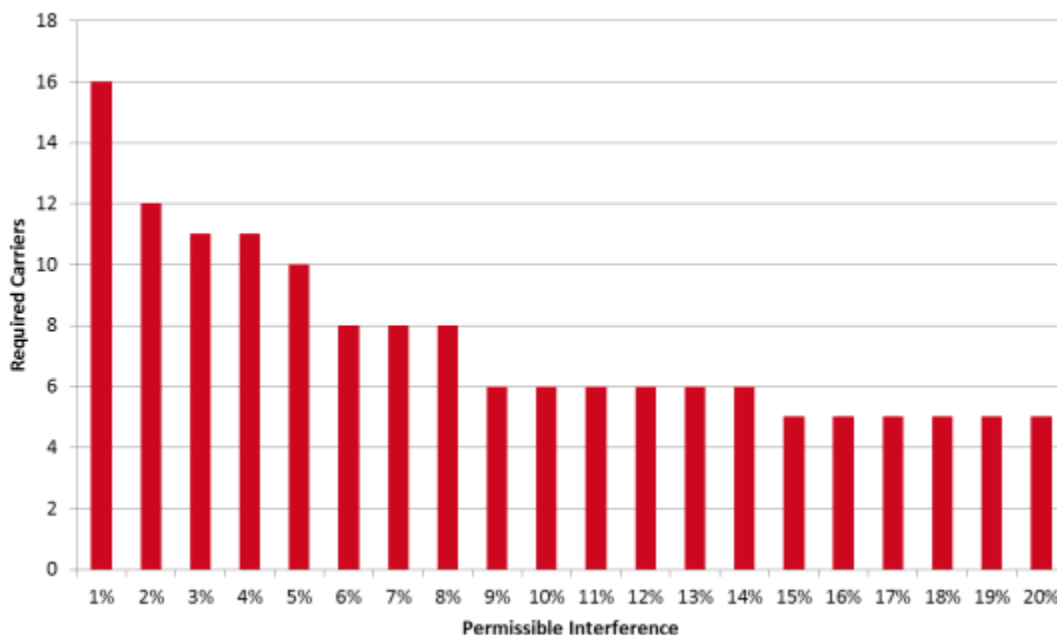

Figure 8-5: Minimum required carries in dependence of permissible interference

It is found that with increasing permissible interference probability the number of required carriers is decreasing and approximating a fixed value of 5 for higher interference probabilities. This figure is dominated by the defined handover relations.

Please also note that the number of required carriers does not indicate if the carriers are required in a continuous bandwidth or if separations between the carries are needed.

The GSM-R system requires the following hardware specific separations between carries:

- Separation of 2 x 200 kHz between centre frequencies of carriers for cells where a handover shall be possible
- Separation of 2 x 200 kHz or 3 x 200 kHz between centre frequencies of carriers operated in the same cell (combiner separation / hardware dependant)
- Separation of 2 x 200 kHz between centre frequencies of carriers operated in the same cell different cells operated at the same site.

We therefore performed a channel assignment for reasonable interference probabilities to verify if the network can be planned with a continuous bandwidth using requirements on hardware separation of 2 x 200 kHz for combiner separation and handover relations.

The following figure shows the resulting C/I for a carrier assignment that used 16 carriers from a continuous bandwidth based on a permissible interference of max. 1 %:

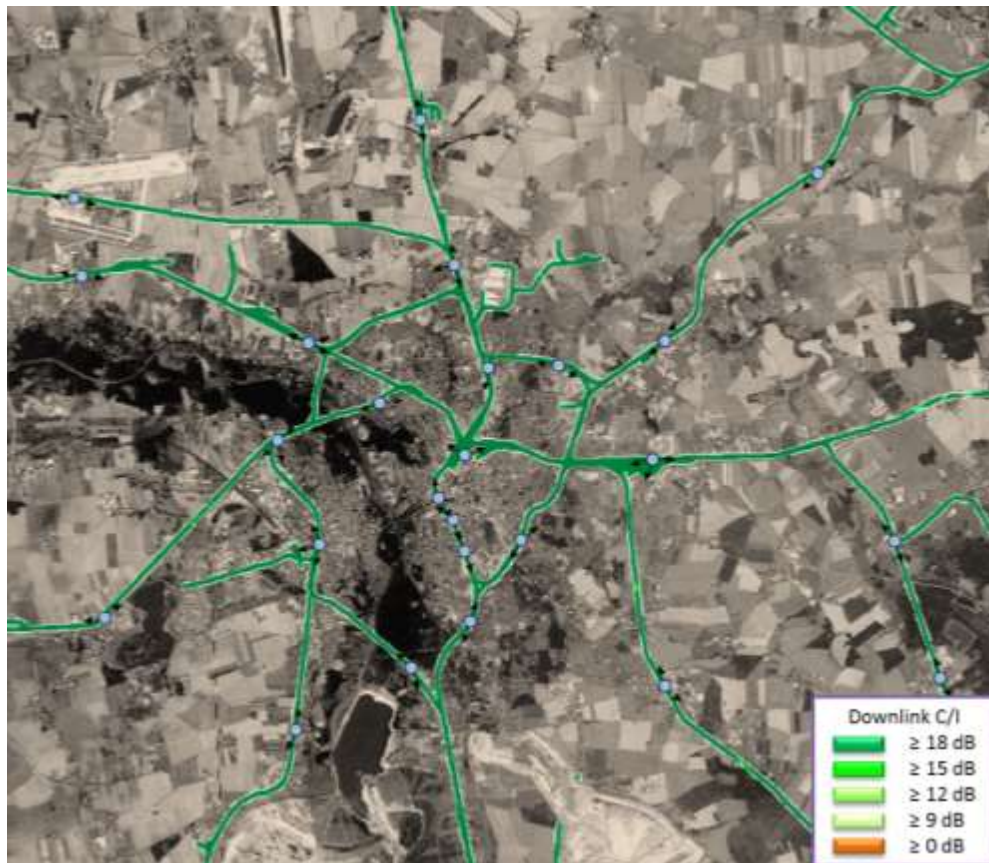

Figure 8-6: Resulting C/I for a frequency assignment using 16 carriers

The comparison with Figure 8-4 shows that the network wide C/I has been slightly improved in comparison to the original frequency plan received from German Railways. This might be due

to the case that not all constraints used during frequency planning by German Railways have been known to us (e.g. avoidance of IM3 from nearby base stations of commercial network operators).

In order to share the R-GSM band with a LTE carrier of 1.4 MHz and a guard band of  $\Delta f=200$  kHz in total  $8 \times 200$  kHz for LTE and the guard band are needed, thus leaving 11 carriers for the GSM-R network. To assess the resulting C/I, we performed a channel assignment using 11 carries in a continuous bandwidth. The resulting C/I is shown below:

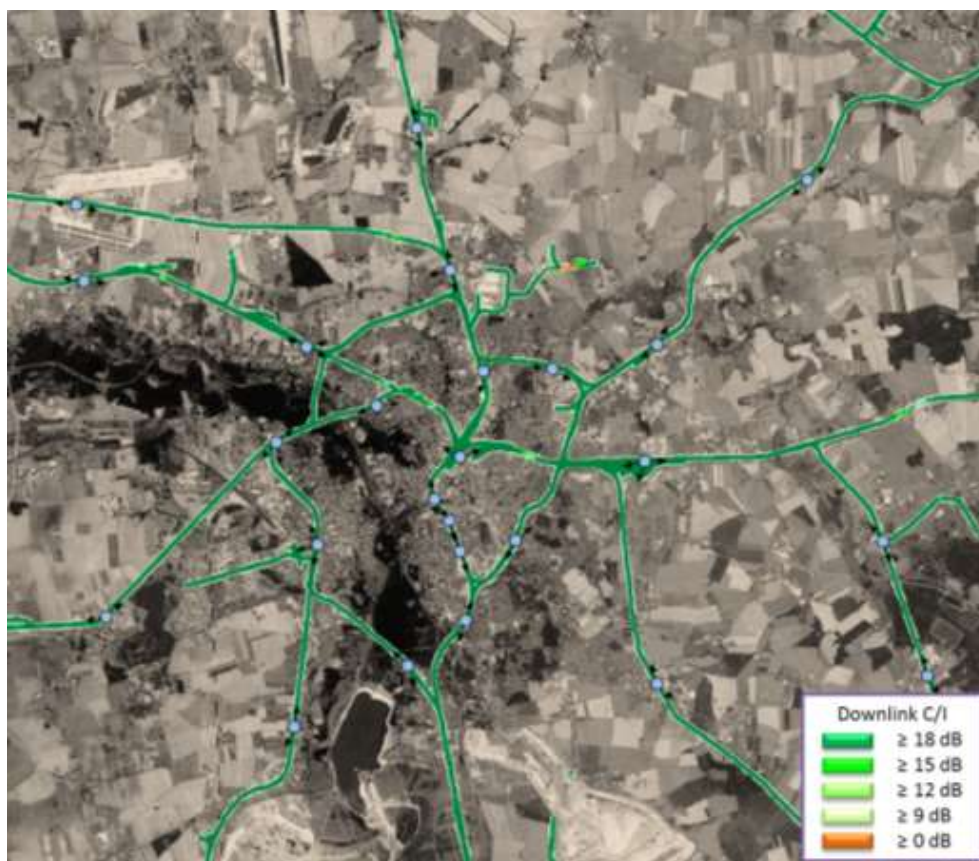

Figure 8-7: Resulting C/I for a frequency assignment using 11 carriers

An comparison of the different C/I plots shows that along few parts of the track the C/I slightly decreases, however still along all target lines a C/I of more than 15 dB can be achieved.

We therefore conclude that the analysed network with the current capacity requirement could be operated with 11 carriers with a degradation of the current quality (i.e. with an increase of the permissible interference between 3 and 4%) and thus an additional LTE carrier with 1.4 MHz could, at least theoretically, be accommodated in the R-GSM band within this area.

In order to analyse the impact of future requirements of capacity increase in the network we further analysed the network under the assumption that each cell in the network will be equipped with an additional TRX, thus any cell in the network will require at least 2 TRX while 5 cells will require 3 TRX. Figure 8-8 repeats the required number of channels for the network around Leipzig main station in dependence of different thresholds for the permissible interference for the current ("as-is") capacity requirement, and also gives the figures for a network with increased capacity requirements:

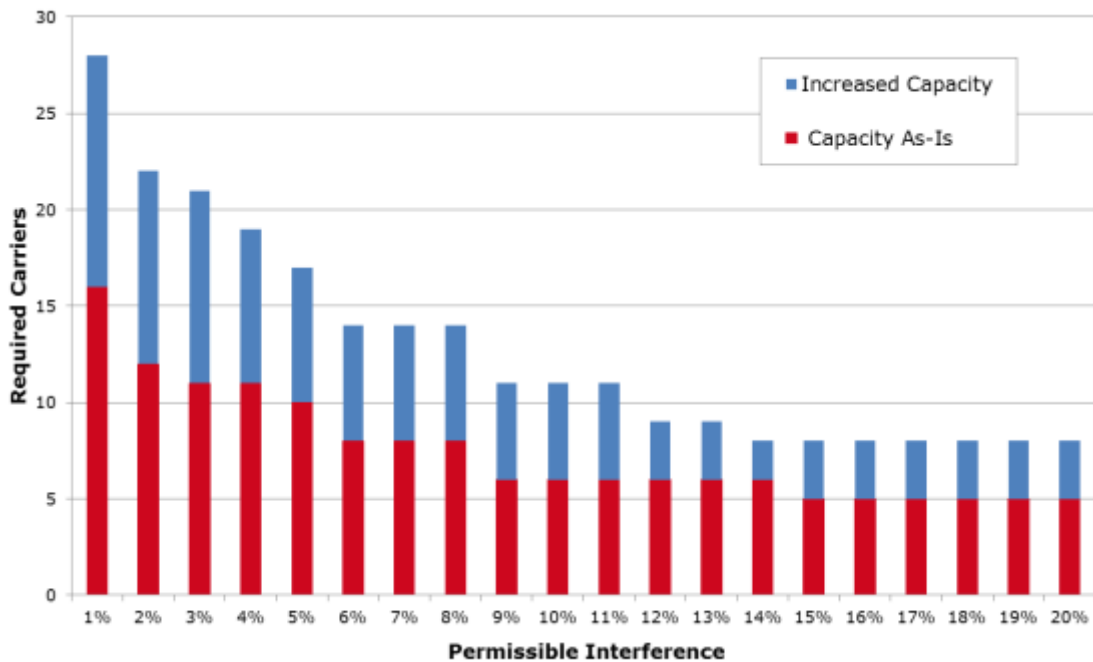

Figure 8-8: Minimum required carriers in dependence of permissible interference for network with "as-is" capacity and increased capacity.

The chart shows, that for reasonable interference probabilities below 5% the network would require between 17 and 28 channels. The use of an additional LTE carrier within the R-GSM band would leave only 11 carriers for the GSM-R system, according to Figure 8-8 this would result in a network interference level of approximately 9% which is unlikely to be acceptable. With 19 usable channels in the R-GSM band, the GSM-R network could be planned with an interference probability of approximately 4 %, if only the R-GSM band was available.

For lower interference probabilities, the joint use of the **R-GSM and the ER-GSM band would be required**. This would allow planning the GSM-R network with an interference probability of approximately 2 to 3% and the parallel use of a 1.4 MHz carrier. Figure 8-9 shows the resulting C/I for a frequency plan that uses 21 channels to accommodate the increased capacity demand. The picture shows that with this amount of channels a comparable C/I for the network with increased capacity demand can be achieved as is found for the network with the existing channel assignment, leaving sufficient bandwidth to include a 1.4 MHz LTE carrier for the new rail radio system if both the R-GSM and ER-GSM bands were available.

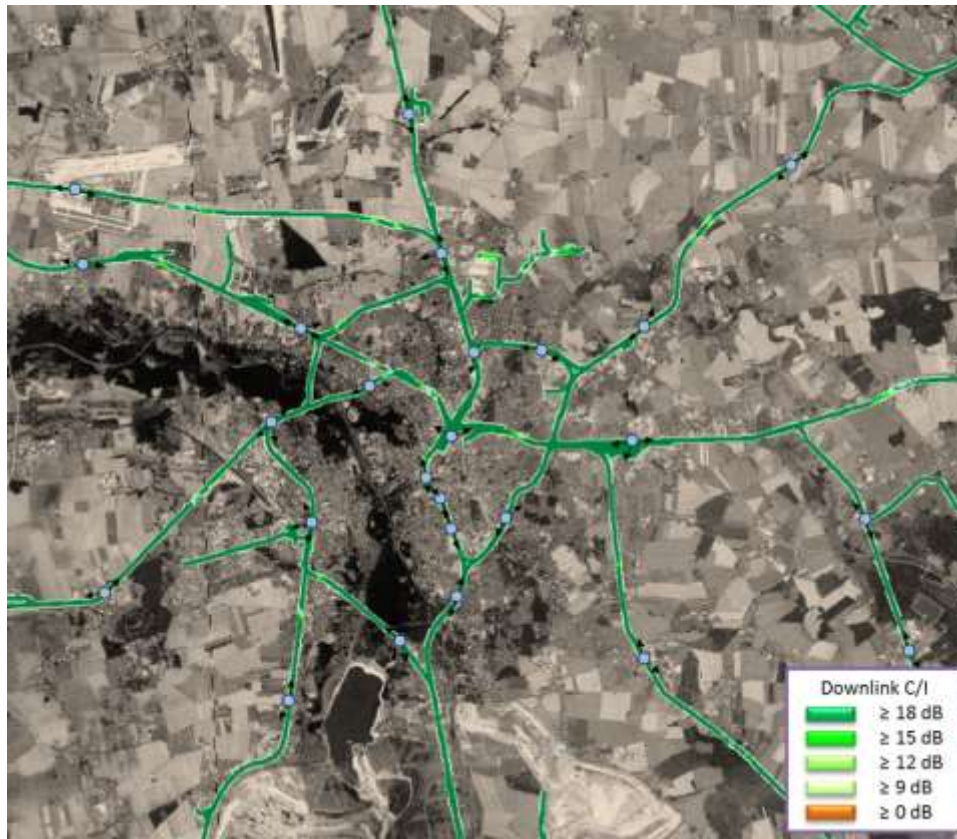

Figure 8-9: Resulting C/I for a frequency assignment using 21 carriers for network with increased capacity requirement

## 8.2 LTE Network

### 8.2.1 LTE Network using same Sites as existing GSM-R Network

In order to assess whether a LTE network using the same sites than GSM-R can provide sufficient coverage along the tracks we simulated LTE network coverage. For this, the GSM-R sites and general antenna configurations have been assumed, but antenna heights have been reduced by 1 m to consider that the antennas are likely to be mounted below the existing GSM-R antennas. The assumed link budgets and system parameter are found in section 9.4.2. During link budget calculations, it has been found that the LTE network is likely limited in the uplink due to the low transmit power of 23 dBm at the UE.

Figure 8-10 shows the maximum achievable net-peak throughput in downlink; Figure 8-11 the maximum achievable net-throughput in uplink for a 1.4 MHz LTE system with SISO (single input, single output) configuration assuming 20 % control overhead in downlink and 15 % control overhead in uplink. The displayed figures are based on the downlink field strength thresholds (see section 9.4.2) and consider a margin of 3 dB for inter cell interference:

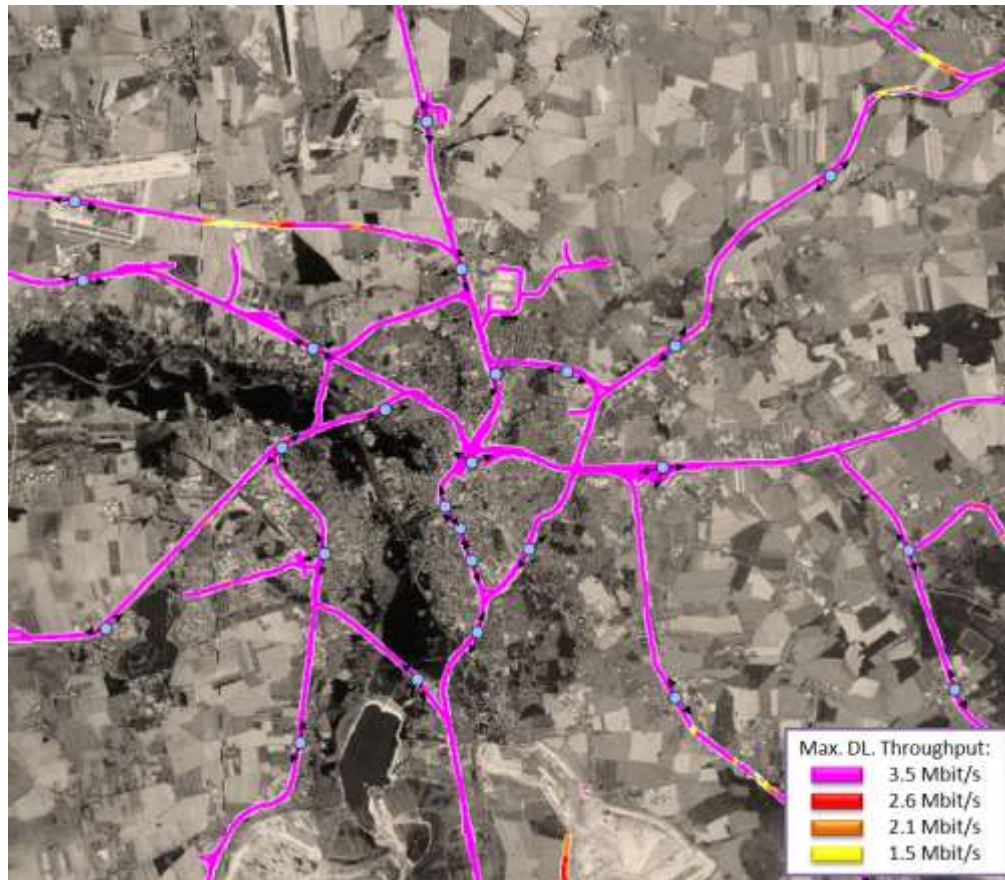

Figure 8-10: Downlink throughput for LTE network using same sites as GSM-R

The downlink plot shows that in wide areas cell peak throughputs of more than 3 Mbit/s can be achieved, in only few areas between widely spaced cells the cell peak throughput is reduced to approximately 800 kBit/s.

In uplink, generally smaller figures for cell throughput are found due to the limited UE transmit power and the resulting weaker uplink budget. Also, the maximum possible uplink modulation scheme has been limited to 16 QAM based on current available handsets. Still, in areas close to the base station, cell peak throughput figures of approximately 1.6 Mbit/s are observed while the minimum found cell throughput at cell borders with low signal level is approximately 0.2 Mbit/s.

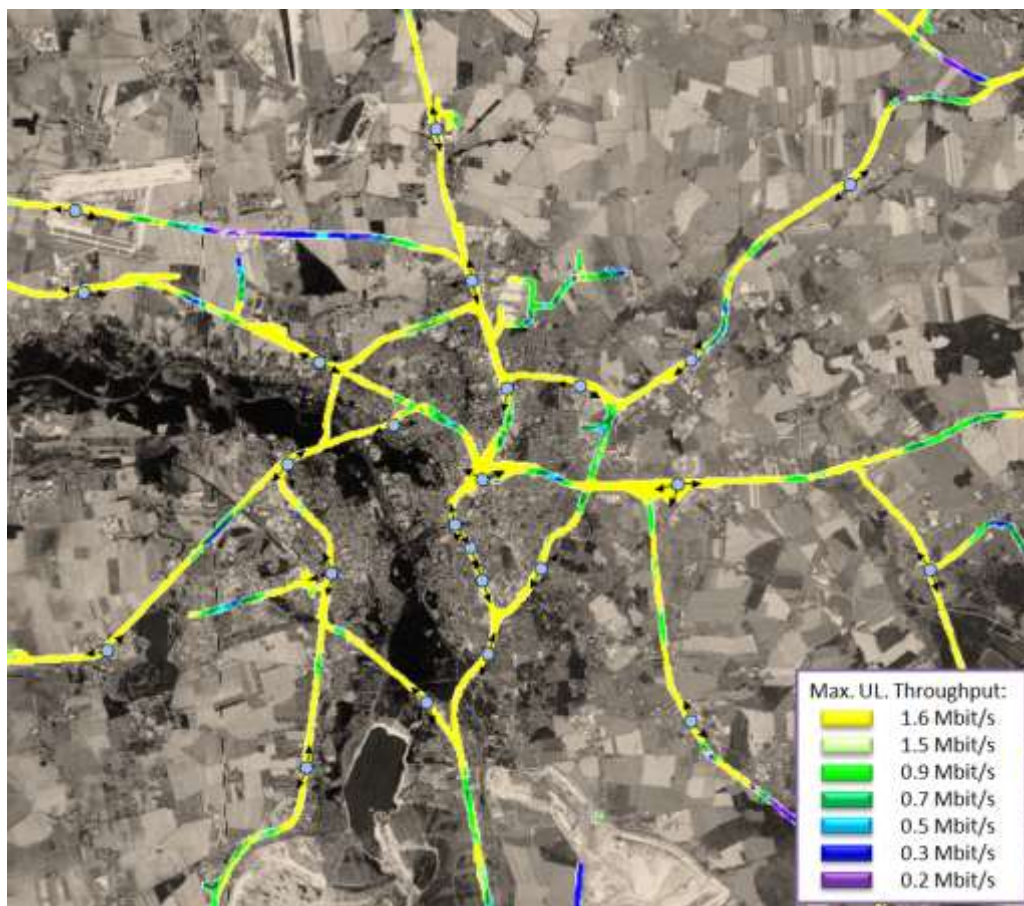

Figure 8-11: Uplink throughput for LTE network using same sites than GSM-R

A legacy GSM-R system using circuit switched data achieves data rates of approximately 9 kBit/s per timeslot. Using GPRS the data rate per time slot will rise to approximately 21.5 kBit/s. Assuming that 8 timeslots are used the cell peak throughput can reach approximately 172 kBit/s (under optimum propagation conditions).

With EGPRS, cell peak throughput of approximately 59 kBit/s can be achieved per time slot assuming optimum propagation conditions. This results in approximately 470 kBit/s cell peak throughput when 8 timeslots are used. However, the cell edge throughput per time slot is reduced to approximately 20 kBit/s [15] resulting in cell throughputs of approximately 160 kBit/s assuming use of 8 timeslots.

Thus, we conclude that the LTE network is capable to provide in downlink at the cell edge higher data rates than a GSM-R network using EGPRS under ideal propagation conditions. Cell edge data rates in uplink are still in the same order than cell edge data rates using EDGE.

It is therefore concluded that a LTE network based on a 1.4 MHz LTE carrier would be capable to take over the traffic carried by an existing GSM-R system using legacy GSM-R CSD technology or more recent EGPRS technology. This assumption is based on the principle that no additional data requirements will exist. Clearly if the rail industry identifies the need for additional data capacity, a 1.4 MHz LTE carrier may not be sufficient.



### 8.2.2 LTE Network using individual Sites

To assess typical inter site distances for a network that would have been individually planned for LTE, hypothetical sites have been placed along the main lines around Leipzig main station. The first station of the design has been located at the same position as the existing GSM-R base station in Leipzig main station while the other sites have been selected in a way that continuous coverage is achieved with maximum inter-site distance.

The resulting network design achieves slightly larger inter site distances than the initial GSM-R network, however it also need to be noted that in the analysed GSM-R network the cell borders are at a rather high level and thus also the GSM-R sites could have been more widely spaced.

The following figures show the achievable throughput in downlink and uplink for a 1.4 MHz LTE system:

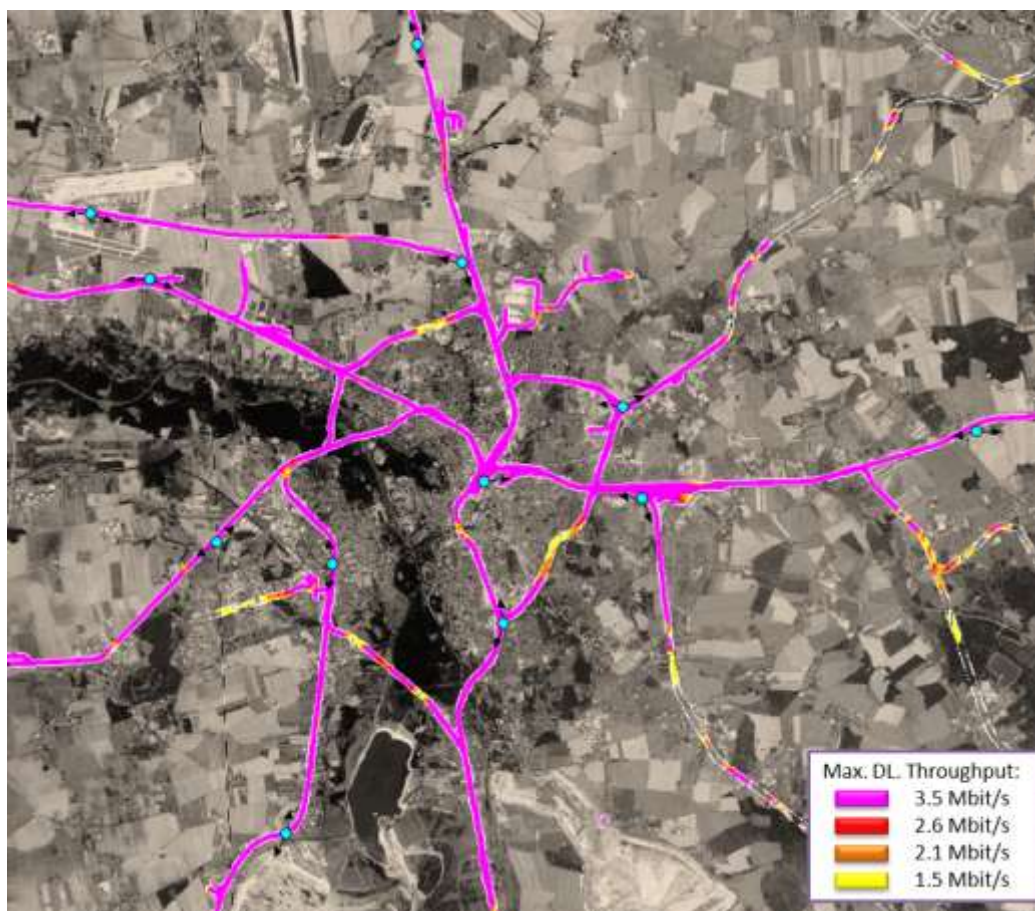

Figure 8-12: Downlink throughput for LTE network using individual sites

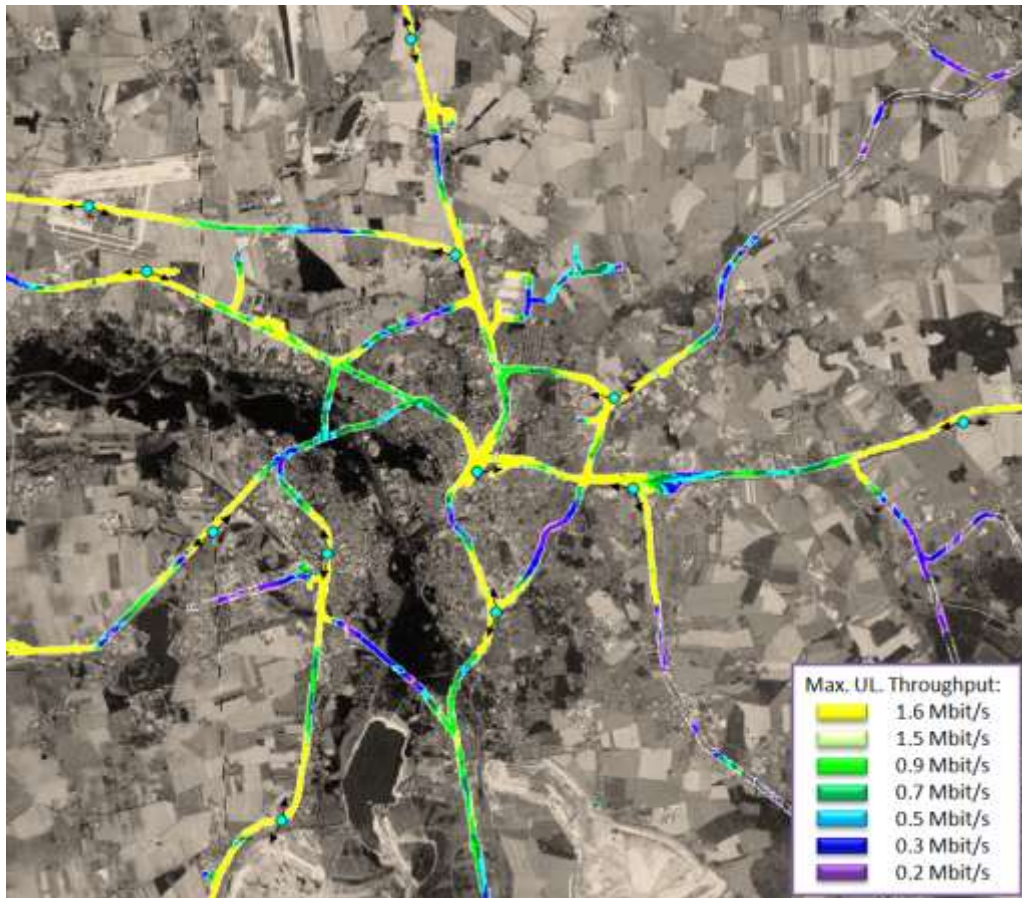

Figure 8-13: Uplink throughput for LTE network using individual sites

Comparing the plots with the scenario where LTE uses the same sites than GSM-R, it is found that in both downlink and uplink the achieved throughput figures are smaller than in the case where same sites are used as GSM-R. This is due to the fact that the sites has been spaced farther apart from each other, which results in reduced downlink receive levels and thus reduced throughput figures. The same result is found for the uplink. However, the data rates achieve in both downlink and uplink at least the cell edge data rates provided by a comparable GSM-R Network using edge. Thus, we conclude that for the considered area a network using individual sites could provide the required coverage with a slightly smaller number of sites than used in the existing network.

However, the reduction in site count is not so large that a completely re-design of the network during migration to LTE would likely be financially beneficial; in areas of hilly terrain the reduction might be even smaller. As site selection processes during network rollout are further not only coverage driven, we anticipate that there would not be a major benefit from not using the sites of an existing GSM-R network.

## 8.3 Situation in Border Regions

### 8.3.1 GSM-R System

The national border closest to Leipzig main station is the border to the Czech Republic. With a distance as the crow flies of approximately 100 km, no specific frequency coordination is required and the entire spectrum allocated to GSM-R is available for the network.

However, in regions closer to the border, the situation is different and frequencies need to be coordinated to avoid cross border interference. To facilitate coordination internationally recommended procedures are in place. Examples are UIC Code 751-4 "The co-ordination of GSM-R systems and radio planning at borders" [10] or ECC Recommendation (05)08 "Frequency Planning and Frequency Coordination for the GSM 900, GSM 1800, E-GSM and GSM-R land mobile systems" [11].

Both documents give guidance on how the requirement for coordination should be determined. According to these recommendations, coordination of a base station should be done if the field strength produced by a carrier of this base station exceeds a value of 19 dBµV/m at 3 m height above ground on the border. To allow simplified coverage planning in border regions, the documents further recommend the split of the available frequency band in preferential and non-preferential frequencies.

For this, each available frequency is allocated to one of the involved countries as preferential frequency, thus being a non-preferential frequency for the other countries. The use of non-preferential frequencies need to be coordinated if the permissible field-strength of 19 dBµV/m is exceeded on the border, while preferential frequencies may be used without coordination, as long as the frequency does not exceed a value of 19 dBµV/m at 3 m height above ground at a distance of 15 km inside the neighbouring country. Thus, base stations using preferential frequencies can operate closer to the border (without need for coordination) than base stations with non-preferential frequencies.

Preferential frequencies and coordination criteria are mutually agreed between countries; the following picture gives some examples of preferential frequency agreements in the R-GSM band. The example for the Bilateral Agreement is based on [13], the examples for the Multilateral Agreements are based on [14]:

Frequency / MHz	876.2	876.4	876.6	876.8	877.0	877.2	877.4	877.6	877.8	878.0	878.2	878.4	878.6	878.8	879.0	879.2	879.4	879.6	879.8	880.0
<b>Bilateral Agreement</b>																				
Country 1 and 2	1	1	1	1	1	2	2	2	2	2	2	2	2	2	2	1	1	1	1	1
<b>Multilateral agreement</b>																				
2 Country Case Country 1 and 2	1	1	2	1	2	1	1	2	2	1	2	2	2	2	2	1	2	1	1	
3 Country Case Country 1, 2 and 3	1	1	2	1	2	1	1	2	3	1	2	3	3	2	3	3	2	3	2	

Figure 8-14: Examples for preferential frequency use. Frequencies marked with "1" are preferential frequencies allocated to country "1" etc.

From the picture, it is found that the agreements typically provide the same or similar number of preferential frequencies per country, either as blocks (as in case of the shown bilateral agreement) or interleaved over the band (as in case of the multilateral agreement).

Thus, using a part of the spectrum for the LTE carrier will not only reduce the spectrum available to GSM-R but could result in an unequal share of preferential frequencies if existing preferential agreements are not modified.

This is illustrated in Figure 8-15, where band 878.6 MHz to 880.0 MHz is reserved for the use of a 1.4 MHz LTE carrier (including a guard band of 200 kHz between the GSM-R and the LTE system):

Frequency / MHz	876.2	876.4	876.6	876.8	877.0	877.2	877.4	877.6	877.8	878.0	878.2	878.4	878.6	878.8	879.0	879.2	879.4	879.6	879.8	880.0
<b>Bilateral Agreement</b>																				
Country 1 and 2	1	1	1	1	1	2	2	2	2	2	2	2								
<b>Multilateral agreement</b>																				
2 Country Case Country 1 and 2	1	1	2	1	2	1	1	2	2	1	2	2								
3 Country Case Country 1, 2 and 3	1	1	2	1	2	1	1	2	3	1	2	3								

Figure 8-15: Examples for preferential frequency use where band 878.6 to 880.0 MHz is used by LTE.

For the shown bilateral agreement the introduction of the LTE carrier would leave approximately the same number of preferential frequencies for both countries, while in the 3 country case, country 3 would remain with only two preferential frequencies.

Thus a re-negotiation of preferential frequency arrangements could be required if the LTE carrier is introduced. Nevertheless, even if a reorganisation is successful only 4 preferential frequencies per country would remain which will be not enough if a high GSM-R base station density (e.g. due to larger stations) is found in border regions.

However, preferential agreements typically also allow for specific frequency usage outside the provisions of the agreement, as long as all involved and affected operators mutually agree. This would either allow negotiating individual agreements for specific regions or to perform a jointly coordinated frequency planning in the border region, which should provide the required flexibility for the frequency assignment.

Such a jointly coordinated frequency planning would also be required in situations, where in one country LTE would be introduced while in a neighbouring country still only GSM-R is in operation. In this case, the spectrum occupied by the LTE carrier in the one country could likely not be used in the border region of the neighbouring country and would therefore need to be vacated by re-planning the GSM-R channel use in the neighbouring country.

### 8.3.2 LTE System

LTE – Networks are typically deployed as single carrier networks, where each base station is using the same centre frequency. Interference between cells is mitigated by the use of Physical-Layer Cell Identities (PCI), which needs to be distributed to cells in a way that a UE does not receive two cells using the same PCI.

The LTE standard defines 168 unique physical-layer cell-identity groups (PCI-group). Each PCI group holds three separate PCIs giving in total 504 PCIs.

ECC Recommendation (08)02 "Frequency planning and frequency coordination for GSM / UMTS / LTE / WiMAX Land Mobile systems operating within the 900 and 1800 MHz bands" [12] describes a procedure, where the available 504 PCI are shared at the border on an equitable basis. Similar like in the case of preferential frequencies for GSM-R each country receives its preferential PCI that can be used close to the border while each country can use all PCI groups away from the border areas.

Such an agreements could also be taken for LTE usage by railways, taking into account that 504 PCI are available the usage of the LTE carrier in border regions should than not be problematic.

### 8.4 Summary of Network Analysis

We modelled a part of a GSM-R and LTE network around Leipzig main station with radio network planning software to determine the impact of the sharing of the GSM-R spectrum with a 1.4 MHz LTE carrier using a guard band of  $\Delta f=200$  kHz.

For this German Railways provided site data of their existing GSM-R network. The data used for the analysis consists of sites in a radius of 20 km around Leipzig main station. The analysed network comprises 34 different sites that use 19 frequencies from the R-GSM band while frequencies from the ER-GSM band are not used. 30 cells use one carrier frequency (TRX) while 5 cells are equipped with 2 TRX.

The analysis focused on the following questions:

- Can the GSM-R network maintain the existing capacity within the reduced spectrum if a 1.4 MHz carrier is introduced?
- Which coverage and throughput would be achieved by an LTE network reusing the sites of the GSM-R network and which coverage and throughput would be found for LTE network using hypothetical sites placed to minimize the LTE site count?

In addition an analysis of the specific situation in border regions has been done.

#### **Analysis of remaining Capacity for the existing GSM-R Network**

The introduction of a 1.4 MHz LTE carrier would occupy 8 x 200 kHz thus leaving 11 carriers for the GSM-R network if only frequencies from the R-GSM band were available. To assess if the existing network could be operated with this reduced spectrum we performed two separate analyses:

- We performed a channel assignment using only 11 carriers from a continuous bandwidth and compared the resulting C/I in the network with the C/I calculated for the existing frequency plan as provided by German Railways. The analysis showed no considerable reduction in the calculated C/I.
- To assess the impact of future capacity extensions we analysed a network where the number of carriers per cell has been increased by one. Our analysis showed that for reasonable interference probabilities below 5% the network would require between 17 and

28 channels. Thus, the joint use of the R-GSM and the ER-GSM band would be needed for such a network.

Thus, we conclude that the current capacity requirement could be operated with 11 carriers with a degradation of the current quality (i.e. with an increase of the permissible interference between 3 to 4 %) and thus an additional LTE carrier with 1.4 MHz could, at least theoretically, be accommodated in the R-GSM band within this area.

### **Analysis of achievable Coverage for the LTE network**

In a second step, two LTE networks have been modelled to analyse network structures required to provide sufficient coverage and throughput.

- In order to assess whether a LTE network using the same sites than GSM-R can provide sufficient coverage along the tracks we simulated LTE network coverage for a network using the existing GSM-R sites. The same antenna configurations have been assumed, but antenna heights have been reduced by 1 m to consider that the antennas are likely to be mounted below the existing GSM-R antennas.
- To assess typical inter site distances for a network that would have been individually planned for LTE, hypothetical sites have been placed along the main lines around Leipzig main station. The first station of the design has been located at the same position as the existing GSM-R base station in Leipzig main station while the other sites have been selected in a way that continuous coverage is achieved with maximum inter-site distance.

The comparison of the two network designs shows that a LTE network using individual sites could result in slightly larger inter-site distances and thus in a reduced site count. However, the achieved throughput in the network using individual sites is smaller than in the case where the GSM-R sites are used due to the reduced receive level at the cell borders.

The reduction in site count is not so large that a completely re-design of the network during migration to LTE would be financially realistic, also considering that in hilly terrain the reduction would be even smaller. As site selection processes during network rollout are further not only coverage driven, we anticipate that there would not be a major benefit from not using the sites of an existing GSM-R network.

Nevertheless, both LTE networks would be capable to provide in downlink at the cell edge higher data rates than a GSM-R network using EGPRS close to the BTS. Cell edge data rates in uplink are still in the same order than cell edge data rates using EDGE. It is therefore concluded that a LTE network based on a 1.4 MHz LTE carrier would be capable to take over the traffic carried by an existing GSM-R system using legacy GSM-R CSD technology or more recent EGPRS technology.

### **Situation in Border Regions**

In regions closer to the border not the full GSM-R spectrum is available, as coordination with GSM-R networks in neighbouring countries is required. For this, preferential frequencies and coordination criteria are mutually agreed between countries; the agreements typically provide the same or similar number of preferential frequencies per country, either as blocks or interleaved over the band.

Thus using a part of the spectrum for the LTE carrier will not only reduce the spectrum available to GSM-R but could also result in an unequal share of preferential frequencies if existing preferential agreements are not modified.

In consequence a re-negotiation of preferential frequency arrangements could be required if the LTE carrier is introduced. Nevertheless, even if a reorganisation is successful only 4 preferential frequencies per country would remain which will be not enough if a high GSM-R

---

base station density (e.g. due to larger stations) is found in border regions. Thus, either individual agreements for specific regions or jointly coordinated frequency planning in the border region would be required to provide the required flexibility for the frequency assignment.

A jointly coordinated frequency planning would also be required in situations, where in one country LTE would be introduced while in a neighbouring country still only GSM-R is in operation. In this case, the spectrum occupied by the LTE carrier in the one country could likely not be used in the border region of the neighbouring country and would therefore need to be vacated by replanting the GSM-R channel use in the neighbouring country.

For coordination of LTE physical-layer cell identities (PCI), similar agreements like used for GSM-R frequencies could be used. There are in total 504 PCIs available so no problems due to shortcomings of PCIs are expected.

## 9 Appendix

### 9.1 Abbreviations

ACIR	Adjacent Channel Interference Ratio
ACK	Acknowledgement Message
ACLR	Adjacent Channel Leakage Ratio
ACS	Adjacent Channel Selectivity
D-AMPS	Digital Advanced Mobile Phone Service
APCO P25	Association of Public-Safety Communications Officials Project 25
BCCH	Broadcast Control Channel
BER	Bit Error Rate
BLER	Block Error Rate
BNetzA	Bundesnetzagentur
BTS	Base Transceiver Station
CDMA	Code Division Multiple Access
CEPT	Conférence Européenne des Administrations des Postes et des Télécommunications
CQI	Channel Quality Indication
CRC	Cyclic Redundancy Check
CSD	Circuit Switched Data
DECT	Digital Enhanced Cordless Telecommunications
DL	Downlink
DME	Distance Measurement Equipment
DMR	Digital Mobile Radio
ECC	Electronics Communications Committee
EDGE	Enhanced Data Rates for GSM Evolution
EGPRS	Enhanced general packet radio service
EIRP	Equivalent Isotropically Radiated Power
EN	European Norm
ETSI	European Telecommunications Standards Institute
FDD	Frequency Division Duplex
FDMA	Frequency Division Multiple Access
3GPP	Third Generation Partnership Project
GPRS	General Packet Radio Service
GSM	Global Standard for Mobile Communications
HSDPA	High Speed Downlink Packet Access
HSPA	High Speed Packet Access
IDEN	Integrated Digital Enhanced Network



---

IEEE	Institute of Electrical and Electronics Engineers
IM	Intermodulation
IMT	International Mobile Telecommunication
IP	Internet Protocol
ITU	International Telecommunications Union
LTE	Long Term Evolution
MCBTS	Multi Carrier Base Transceiver Station
MFCN	Mobile/Fixed Communications Networks
MIMO	Multiple Input Multiple Output
MS	Mobile Station
NACK	Non-Acknowledgement Message
NGMN	Next Generation Mobile Networks Alliance
NGTC	Next Generation Train Control
NXDN	Next Generation Digital Narrowband
OFDM	Orthogonal Frequency Division Multiplex
OFDMA	Orthogonal Frequency Division Multiple Access
OOB	Out of Band Emissions
PCI	Physical-Layer Cell Identity
PDC	Personal Digital Cellular
PDSCH	Physical Downlink Shared Channel
PMI	Precoding Matrix Indicator
PMR	Public Mobile Radio
PRBS	Pseudo Random Binary Sequence
PUSCH	Physical Uplink Shared Channel
QAM	Quadrature Amplitude Modulation
QPSK	Quaternary Phase Shift Keying
RF	Radio Frequency
RFID	Radio Frequency Identification
RI	Rank Indicator
RX	Receive
SISO	Single Input Single Output
SRD	Short Range Device
TBS	Transport Block Size
TCH	Traffic Channel
TDD	Time Division Duplex
TEDS	TETRA Enhanced Data Services
TETRA	Terrestrial Trunked Radio Access
TPC	Transmit Power Control

---

---

TR	Technical Report
TRX	Transmit-Receive Unit
TS	Technical Specification
TU	Technische Universität
TX	Transmit
UE	User Equipment
UIC	Union Internationale des Chemins de Fer / International Union of Railways
UK	United Kingdom
UL	Uplink
UMB	Ultra Mobile Broadband
UMTS	Universal Mobile Telecommunications System
USB	Universal Serial Bus
UTRA	Universal Terrestrial Radio Access
WLAN	Wireless Local Area Network

## 9.2 References

- [1] CEPT Report 40 "Compatibility study for LTE and WiMAX operating within the bands 880-915 MHz / 925-960 MHz and 1710-1785 MHz / 1805-1880 MHz (900/1800 MHz bands)", November 2010
- [2] CEPT Report 41 "Compatibility between LTE and WiMAX operating within the bands 880-915 MHz / 925-960 MHz and 1710-1785 MHz / 1805-1880 MHz (900/1800 MHz bands) and systems operating in adjacent bands", November 2010
- [3] ECC Report 146 "Compatibility between GSM MCBTS and other services (TRR. RSBN/PRMG. HC-SDMA. GSM-R. DME. MIDS. DECT) operating in the 900 and 1800 MHz frequency bands", June 2010
- [4] ECC Report 162 "Practical Mechanisms to improve the compatibility between GSM-R and public mobile networks and guidance on practical coordination", May 2011
- [5] FM(13)134 "BNetz-A Measurement Report: Compatibility measurements GSM/UMTS/LTE VS. GSM-R" (Version 3.0), September 2013
- [6] ECC Report 229 "Guidance for improving coexistence between GSM-R and MFCN in the 900 MHz band", May 2015
- [7] "UMTS – GSM-R Interference Measurement – A Report Prepared for Ofcom", Ofcom/Red-M, June 2011
- [8] FM54(14)04rev-1 "Analysis of Field Testing Results of Mobile Operator GSM & UMTS Interference on Network Rail GSM-R Mobiles / Laboratory Test Report (Redacted)", NetworkRail/Red-M, March 2012
- [9] ITU-R M.2244 "Isolation between antennas of IMT base stations in the land mobile service", ITU-R. Geneva 11 2011
- [10] UIC Code 751-4 "The co-ordination of GSM-R systems and radio planning at borders" International Union of Railways", 12/2005
- [11] ECC Recommendation (05)08 "Frequency Planning and Frequency Coordination for the GSM 900, GSM 1800, E-GSM and GSM-R land mobile systems"
- [12] ECC Recommendation (08)02 "Frequency planning and frequency coordination for GSM / UMTS / LTE / WiMAX Land Mobile systems operating within the 900 and 1800 MHz bands"
- [13] "Agreement between the National Post and Telecom Agencies in Norway and Sweden concerning the use of frequency bands 876 – 88 MHz and 921 – 925 MHz for GSM-R in the border areas", 2003
- [14] "Agreement between the Administrations of Austria, the Czech Republic, Germany, Hungary the Slovak Republic and Slovenia on the frequency coordination in the frequency bands 876 -880/921 – 925 MHz)", Vienna, 26 February 2003

- 
- [15] "GSM/EDGE: Evolution and Performance"  
Mikko Saily, Guillaume Sebire, Dr. Eddie Riddington  
Wiley, 2011
  - [16] "LTE for UMTS, Evolution to LTE-Advanced – Second Edition"  
Harry Holma and Antti Toskala  
Wiley, 2011
  - [17] 3GPP TR 25.814, "Physical Layer Aspects for Evolved UTRA"
  - [18] 3GPP-TS 36.101, "3rd Generation Partnership Project; Technical Specification Group Radio Access Network; Evolved Universal Terrestrial Radio Access (E-UTRA); User Equipment (UE) radio transmission and reception (Release 12)"
  - [19] 3GPP-TS 36.104, "LTE; Evolved Universal Terrestrial Radio Access (E-UTRA); Base Station (BS) radio transmission and reception (3GPP TS 36.104 version 12.10.0 Release 12)"
  - [20] 3GPP TS 45.005, "3rd Generation Partnership Project; Technical Specification Group GSM/EDGE Radio Access Network; Radio transmission and reception"
  - [21] ETSI EN 301 908-13, "IMT cellular networks; Harmonised Standard covering the essential requirements of article 3.2 of the Directive 2014/53/EU; Part 14: Evolved Universal Terrestrial Radio Access (E-UTRA) User Equipment (UE)"
  - [22] ETSI EN 301 908-14, "IMT cellular networks; Harmonised Standard covering the essential requirements of article 3.2 of the Directive 2014/53/EU; Part 14: Evolved Universal Terrestrial Radio Access (E-UTRA) Base Stations (BS)"
  - [23] "ZTE's Magic Radio 4G LTE Solution Delivers 50% Spectral Gain for China Unicom"  
ZTE Press Release, 16.09.2015  
[http://www.zte.com.cn/en/press\\_center/news/201509/t20150916\\_444473.html](http://www.zte.com.cn/en/press_center/news/201509/t20150916_444473.html)
  - [24] "LTE 1800MHz Ecosystem Drivers"  
Huawei publication, March 2003
  - [25] "1800 MHz: The key to LTE worldwide"  
Huawei publication, June 2013
  - [26] "Introducing LTE with maximum reuse of GSM assets"  
White Paper Nokia Siemens Networks, 2011

### 9.3 Other Studies with relevance for this Work

Coexistence of GSM-R with other mobile radio systems has been widely analysed during the last years with focus on interference from and to public mobile networks and the corresponding radio technologies like UMTS and LTE. The commercial GSM bands are adjacent to the GSM-R band with direct adjacencies at 880 MHz for uplink bands and at 925 MHz for downlink bands. The commercial bands initially have been licensed for use with GSM technology only, yet the situation has become more severe during the last years as the recent technology neutral licensing regime has opened the band to other radio technologies like UMTS and LTE and thus there has been a need to evaluate coexistence between GSM-R and these technologies.

We reviewed relevant studies and identified a range of documents that could provide valuable input to our work. These documents are:

- CEPT Report 40 on the sharing of public GSM-Bands between GSM and LTE/WiMAX [1].
- CEPT Report 41 on the compatibility between LTE/WiMAX operating within the 900/1800 MHz bands and systems operating in adjacent bands e.g. GSM-R in the R-GSM and ER-GSM band [2].
- ECC Report 146 on compatibility between GSM MCBTS and other services (TRR, RSNB/PRMG, HC-SDMA, GSM-R, DME, MIDS, DECT) operating in the 900 and 1800 MHz frequency bands.[3]
- ECC REPORT 162 focusing on coexistence between public mobile networks operating in the 900 MHz band and GSM-R networks operating both in the R-GSM band the ER-GSM band. [4]
- Report FM(13)134\_GSM-R details results from measurements for compatibility between GSM/UMTS/LTE and GSM-R performed by the German BNetzA [5]
- ECC Report 229 gives guidance to improve coexistence between GSM-R and MFCN in the 900 MHz band [6].

The frequency arrangements for co-sharing of systems within the GSM-R band are different to the ones for coexistence between GSM-R and public mobile networks. Furthermore, the coverage and capacity requirements between networks dedicated to railway use and public mobile networks are not the same resulting in dissimilar conditions for network deployment (e.g. site locations, terminal positions). Therefore, the results given in the other studies need modification or refinement due to the differences between the cases to analyse.

The following table gives an overview on the scope and relevant results of the different studies. Some of the studies cover more systems than LTE and GSM-R (e.g. WiMAX sometimes also LTE/WiMAX in combination, DECT, GSM etc.). However, for purpose of simplicity, only LTE is mentioned in the ongoing text.

Report	Summary
CEPT Report 40	This report studies the sharing of public GSM-Bands 880-915 MHz / 925-960 MHz and 1710-1785 MHz / 1805-1880 MHz between GSM and LTE. The report states that compatibility is given for frequency separations of 200 kHz or more between LTE channel edge and the GSM carrier's channel.
CEPT Report 41	This report studies compatibility between LTE operating within the 900/1800 MHz bands and systems operating in adjacent bands e.g. GSM-R in the R-GSM and ER-GSM band.

	<p>The report draws the following conclusions:</p> <ul style="list-style-type: none"> <li>▪ In general, there is no guard band required, in specific cases a separation of 200 kHz or more between LTE channel edge and the GSM carrier's channel edge is needed.</li> <li>▪ LTE BTS operation in 925 MHz band can result in interference to GSM-R mobile stations in some critical cases like high located antenna for LTE BTS and GSM-R signal close to the sensitivity level. A distance of up to 4 km or more from LTE BTS to the railway track might be needed.</li> <li>▪ GSM-R MS operation might result in reduced capacity of LTE Base stations operating above 880 MHz. Power control at GSM-R MS could be used to mitigate this effect.</li> <li>▪ LTE UE operating at 915 MHz band edge is unlikely to cause interference to GSM-R MS operating in ER-GSM band. However, detailed analyses have not been done.</li> <li>▪ GSM-R BTS in Band 918 MHz and above may cause desensitization and blocking to LTE BTS operating below 915 MHz.</li> </ul>
ECC Report 146	<p>This report studies the compatibility between GSM MCBTS and GSM-R (in the GSM-R band).</p> <p>While this interference scenario is not directly related to the scope of our work, the report gives reference to some like blocking behaviour of GSM-R terminals and network simulation scenarios that are of interest for our study.</p> <p>The report concludes that under certain worst-case conditions the GSM-R network can experience interference, with the dominating interference effects being the blocking and adjacent channel performance of the GSM-R terminal.</p>
ECC Report 162	<p>This report focuses on the coexistence between public mobile networks operating in the 900 MHz band and GSM-R networks operating both in the R-GSM and the ER-GSM band. Where applicable the report cites results from ECC Reports 96 and 146 and CEPT Report 41. In addition, specific scenarios in relation to compatibility with UMTS 900 and ER-GSM covered by these reports have been analysed within ECC Report 162.</p> <p>Aside a summary on compatibility analyses the report discusses a range of mitigation techniques to address compatibility issues.</p>
Report FM(13)134_GSM-R	<p>This report describes compatibility measurements between GSM-R terminal receivers (wanted signal), operating below 925 MHz, and the public mobile systems GSM, UMTS and LTE (interfering signals), operating in the band above 925 MHz. The following results have been found:</p> <ul style="list-style-type: none"> <li>▪ The interference potential of LTE/5MHz and LTE/10MHz is equal.</li> <li>▪ In the presence of one LTE broadband interferer the GSM-R receivers do not show a pure blocking behaviour. Instead, they seem to be affected by intra-signal intermodulation where one part of the interfering LTE signal intermodulates with another part of its own spectrum.</li> <li>▪ The interference level where intermodulation begins in front of a LTE signal is about 6 dB higher than in front of two GSM signals. However, when this happens, often the whole R-GSM band is affected by intermodulation, whereas when GSM signals interfere, only a limited number of GSM-R channels are affected.</li> <li>▪ In the standard GSM-R receiver, intermodulation becomes dominant at GSM-R signal levels higher than about -95 dBm (realistic interferer) and -80 dBm (standard interferer) unless the frequency separation between both signals is less than about 800 kHz (GSM) or 4 MHz (LTE/5MHz), respectively.</li> <li>▪ For GSM-R signal levels below about -95 dBm, and generally for frequency separations less than about 4 MHz (LTE) or 800 kHz (GSM), the dominating</li> </ul>

	<p>interference effect comes from the unwanted emissions.</p> <ul style="list-style-type: none"> <li>▪ The unwanted emissions of LTE signals have between 10 to 20 dB more interference potential than a GSM signal. The reason for this is the spectrum mask for UMTS and LTE (according to the specifications) that is less stringent than for GSM.</li> </ul>
ECC Report 229	<p>ECC Report 229 gives an overview on relevant railway specifications for interoperability and the underlying legal framework and sketches and generic coordination and cooperation process. From a technical point of view, it makes reference to Report FM(13)134_GSM-R and derives some intermodulation thresholds. It further gives a methodology how coordination requirements can be derived by calculating the permissible OOB emission of an adjacent system that could be accepted at the train antenna.</p>

When comparing the scope of the different studies against the scope of our work, it is evident, that CEPT Report 40 fits best to the task of analysing in-band compatibility of LTE and GSM-R in the ER/R-GSM bands. Under the assumption that equipment for the public 900 MHz bands and GSM-R and LTE equipment for the R-GSM bands have the same RF characteristics (e.g. same spectrum mask, same blocking probabilities etc.), the results of CEPT Report 40 should be directly applicable to sharing of LTE and GSM-R in the R-GSM bands.

However, comparing the results of CEPT Report 40 on in-band sharing against the results of CEPT Report 41 that covers sharing in adjacent bands raises some questions. CEPT Report 41 indicates for example that a GSM-R BTS operating in the Band 918 MHz and above may cause desensitization and blocking to LTE BTS operating below 915 MHz. This means that a channel separation of 200 kHz or more between LTE channel edge and the GSM carrier's channel might not be sufficient to achieve compatibility.

This is further underlined by the results of BNetzA measurements, documented in report FM(13)134\_GSM-R, that clearly states that there are several interference effects that are dominating the interference situation and are not covered by the "classical" sharing calculations based on spectrum masks and generic system parameter, like ACLR, ACIR and blocking thresholds as used in the CEPT reports. Especially intermodulation products in downlink resulting from different signals like GSM-R, GSM and LTE from public mobile operators falling into the receive bandwidth of GSM-R mobile receivers have been described. Similar effects of intermodulation between GSM-R, GSM and UMTS in the 900 MHz bands have also been observed during measurement campaigns in UK ([7][8]).

## 9.4 Link Budgets

### 9.4.1 GSM-R Link Budget

The following tables give the link budget calculation in uplink and downlink for a GSM-R train mounted mobile station:

Parameter	Value	Unit
<b>Transmitter: MS</b>		
Max Tx Power	39.00	dBm
Cable Loss	3.00	dB
Tx antenna gain	5.00	dBi
EIRP	41.00	dBm
<b>Receiver: BTS</b>		
Receiver Sensitivity	-104.00	dBm
Rx Diversity Gain	3.00	dB
Effective BTS Sensitivity	-107.00	dBm
Cable and Coupling Losses (including 3 dB coupler at the antennas)	6.00	dB
Rx Antenna Gain	18.00	dBi
<b>Maximum Uplink Path Loss</b>		
	<b>160</b>	<b>dB</b>

Table 9-1: GSM-R link budget for uplink

Parameter	Value	Unit
<b>Transmitter: BTS</b>		
Max Tx Power	44.00	dBm
Cable and Coupling Losses (including 3 dB coupler at the antenna)	6.00	dB
Tx Antenna Gain	18.00	dBi
EIRP	56.00	dBm
<b>Receiver: MS</b>		
Receiver Sensitivity	-104	dBm
Cable Loss	3.00	dB
Rx Antenna Gain	5.00	dBi
<b>Maximum Downlink Path Loss</b>		
	<b>162.00</b>	<b>dB</b>

Table 9-2: GSM-R link budget for downlink



To determine the threshold to be used for visualization in the planning software using downlink field strength calculations the minimum path loss has been used and a fade margin for 95% coverage probability applied:

Parameter	Value	Unit
Path loss Uplink	160	dB
Path loss Downlink	162	dB
Minimum Path loss to consider	160	dB
EIRP Downlink	56.00	dBm
Path loss to consider	159.96	dB
Threshold at cell edge (50%)	-106.96	dBm
Slow Fade Margin	7	dB
Threshold cell edge (95%)	-97	dBm

Table 9-3: Calculation of GSM-R planning thresholds

### 9.4.2 LTE Link Budget

The following tables give the link budget calculation in uplink and downlink for train mounted LTE user equipment. A standard transmit power of 23 dBm has been assumed:

Parameter	Value	Unit
<b>Transmitter: UE</b>		
Max Tx Power	23.00	dBm
Tx antenna gain	5.00	dBi
Cable Loss	3.00	dB
EIRP	25.00	dBm
<b>Receiver: eNodeB</b>		
Reference Sensitivity (QPSK 1/3)	-106.80	dB
Correction to QPSK 1/8	-4.10	dBm
Receiver Sensitivity	-110.90	dBm
Interference Margin	1.00	dB
Cable Loss (including 3 dB coupler at the antennas)	6.00	dB
Rx Antenna Gain	18.00	dBi
RX Diversity Gain	3.00	dB
<b>Maximum Path Loss</b>	<b>149.90</b>	<b>dB</b>

Table 9-4: LTE link budget in uplink

Parameter	Value	Unit
<b>Transmitter: eNodeB</b>		
Max Tx Power	43.00	dBm
Tx antenna gain	18.00	dBi
Cable and Coupling Losses (including 3 dB coupler at the antennas)	6.00	dB
EIRP	55.00	dBm
<b>Receiver: UE</b>		
Reference Sensitivity (QPSK 1/3)	-102.20	dBm
Correction to QPSK 1/8	-4.10	dB
Receiver Sensitivity	-106.30	dBm
Interference Margin	4.00	dB
Cable Loss	3.00	dB
Rx Antenna Gain	5.00	dBi
Control Channel Overhead	20.00	%
Control Channel Overhead	0.97	dB
<b>Maximum Path Loss</b>	<b>158.33</b>	<b>dB</b>

Table 9-5: LTE link budget in downlink

To determine the threshold to be used for visualization in the planning software using downlink field strength calculations the minimum path loss has been used and a fade margin for 95% coverage probability applied. The system is limited in uplink by approximately 8 dB due to the low transmit power at the UE:

Parameter	Value	Unit
Path loss Uplink	149.90	dB
Path loss Downlink	158.33	dB
Path loss to consider	149.90	dB
EIRP Downlink	55.00	dBm
Path loss to consider	149.90	dB
Threshold min data rate at cell edge (50 %)	-94.90	
Slow Fade Margin	7.00	dB
Threshold min data rate at cell edge (95 %)	-87.90	dBm

Table 9-6: Calculation of LTE planning thresholds

Table 9-7 shows the resulting thresholds to be used to visualize the different possible throughputs in uplink and downlink for a 1.4 MHz LTE carrier:

CQI	Gross-Throughput kBit/s	Net-Throughput kBit/s (20% control overhead)	DL Threshold dBm	Net-Throughput kBit/s (15% control overhead)	UL Threshold dBm
1	208	166	-87.90	176	-88.90
2	328	262	-87.90	278	-86.70
3	408	326	-87.90	346	-85.50
4	504	403	-87.90	428	-84.80
5	600	480	-87.90	510	-81.80
6	712	569	-87.90	605	-79.50
7	808	646	-87.90	686	-78.30
8	936	748	-87.90	795	-77.60
9	1032	825	-87.90	877	-75.90
10	1352	1081	-87.90	1149	-72.50
11	1736	1388	-87.90	1475	-71.60
12	1928	1542	-87.90	1638	-71.00
13	2600	2080	-86.90	2210	-68.50
14	3240	2592	-84.70	2754	-66.30
15	4392	3513	-83.60	3733	-65.20

Table 9-7: Thresholds for throughput visualization in uplink and downlink